

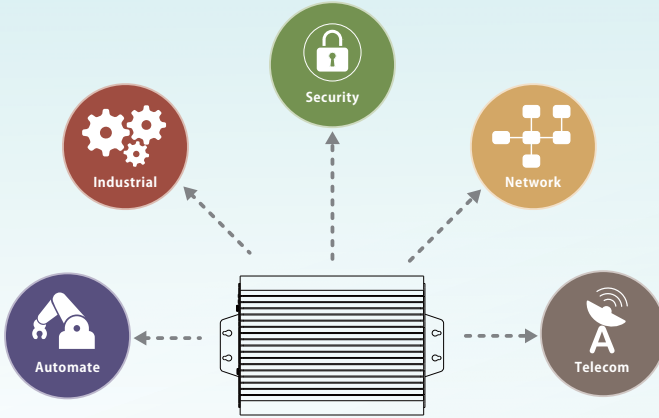

HEP-2300 Series Installation manual



Switching Power Supply for Harsh Environment

- High efficiency
- Filling with heat-conducted glue
- Conduction cooling

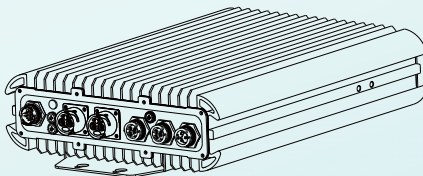
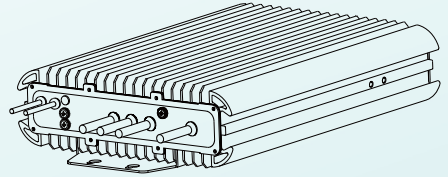
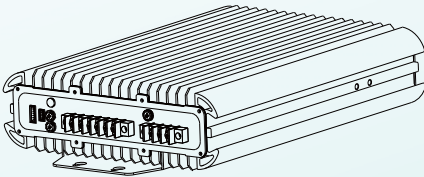

HEP-2300 is a 2300W industrial AC/DC power supply featuring the outstanding capability to operate under highly humid, dusty, oily, and high-vibration harsh environment. The entire series is housed with the aluminum case and fully potted with heat-conducted glue. Adopting the full range 90~305VAC input, the entire series provides an output voltage line of 55/115/230/380VDC. In addition to the high efficiency up to 95.5%, that the whole series operates from -40°C ~ 70°C under air convection without fan. HEP-2300 has the complete protection functions and 10G anti-vibration capability; It is complied with the international safety regulations such as TUV EN62368-1 UL62368-1 and design refers to EN61558-1 and EN60335-1. HEP-2300 series serves as a high performance power supply solution for various industrial and telecom applications. In addition, the 55V model also supports charge function for lead-acid and lithium-ion batteries.

Contents

1.Safety Guidelines	1	5.7 Remote Control	30
2.Introduction	2	5.8 DC-OK Signal	31
2.1 Model Encoding	2	5.9 Auxiliary Output	31
2.2 Features	3	5.10 Charging(55V only)	31
2.3 Specification	4	5.11 Factory Resetting	35
2.4 Derating curve	8	6.Communication Protocol	36
2.5 Mechanical specification	9	6.1 PMBus Communication	36
2.6 Output Type	10	Interface	
2.7 Accessory List	10	6.2 CANBus Communication	43
(Optional equipment)		Interface	
3.Installation & Wiring	11	6.3 Modbus Communication	56
3.1 Mounting	11	Interface	
3.2 Wiring	16	6.4 Value range and tolerance	72
3.3 DC Cable Size Selection	17	7.Protections and Trouble	75
4.Panel and LED indicator	18	Shooting	
4.1 Terminal	18	7.1 Protections	75
4.2 Wiring	21	7.2 Trouble Shooting	76
4.3 Harness connector type	24	8.Warranty	77
(55V only)			
4.4 LED Indicator	26		
5.Operation	27		
5.1 Function Difference	27		
5.2 Application Examples of	27		
Different Output Forms			
5.3 Inrush Current Limiting	28		
5.4 Power Factor Correction	28		
(PFC)			
5.5 Output Voltage Adjustment	28		
5.6 Output Current Adjustment	29		

1.Safety Guidelines

- Risk of electrical shock and energy hazard, all failure should be examined by a qualified technician. Please do not remove the case from the power supply by yourself.
- Please do not change any component on the unit by yourself or make any kind of modification on it.
- The AC voltage range is 100 – 277Vac (47 – 63Hz), please do not connect the supply to AC gird out of the range.
- Please do not stack any object on the unit.
- The safety protection level of this supply is class I. The “Frame Ground” (≠) of the unit must be well connected to PE (Protective Earth).
- The device should be installed in a Restricted Access Location, such as telecommunication facilities, and accessible only to skilled persons.

! WARNING: For 115V/230V/380V models

⚠ Burn hazard, the surface becomes hot while operating. If maintenance is required, please turn off the device for at least 30 minutes to cool down before touching.

! Attention : Modèles 115V/230V/380V uniquement

⚠ Risque de brûlure, la surface devient chaude pendant l'opération. Si un entretien est requis, veuillez éteindre l'appareil pendant au moins 30 minutes pour refroidir avant de le toucher. l'appareil doit être installé dans un endroit à accès restreint, tels que les installations de telecommunication, et accessible uniquement aux personnes compétentes.

2.Introduction

2.1 Model Encoding

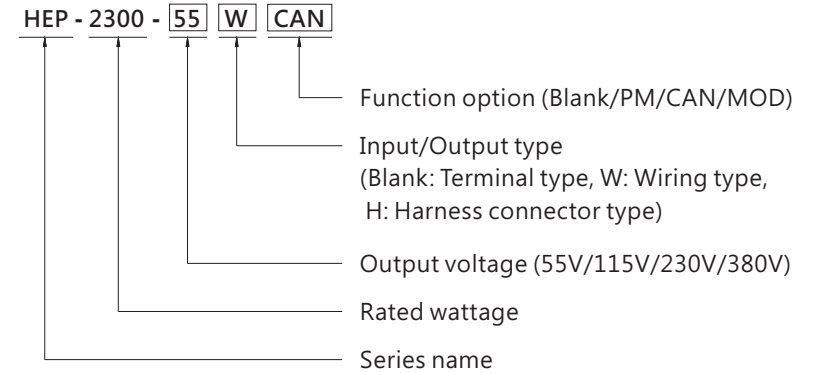

I/O Type	Function type	Communication Protocol	Note
Terminal	Blank	CANBus and PV/PC programmable	In Stock
	PM	PMBus and PV/PC programmable	By request
Wiring	Blank	PV/PC programmable	In Stock
	PM	PMBus	By request
	CAN	CANBus	By request
Harness connector (55V only)	Blank	CANBus	In Stock
	PM	PMBus	By request
	MOD	Modbus-RTU/RS-485	By request

Note: 1.MEAN WELL can provide complete cable modification services. Please contact sales representatives for details.
 2.Charger function by programmer or PMBus/CANBus/Modbus setting (55V only).

2.2 Features

- Various Output voltage: 55V/115V/230V/380VDC
- High efficiency up to 95.5% and active PFC function
- Fanless design, cooling by free air convection
- Aluminum case and filling with heat-conducted glue
- Withstand 10G vibration test
- -40 ~ +70°C wide operating range
- Charger function for lead-acid batteries and Li-ion batteries(55V only)
- Built-in default 2/3 stage charging curves and programmable curve(55V only)
- Built-in CANBus and PMBus / Modbus by optional (Modbus 55V only)
- Output voltage and constant current level programmable
- Protections: Short circuit / Overload / Over voltage / Over temperature
- Built-in remote ON-OFF control and DC OK active signal
- Harness connector type with AC fail and T-Alarm signal
- LED indicator for power on
- Diverse installation scenarios-Mounting methods
- 6 years warranty

2.3 Specification

HEP-2300-55 series-Switching Power Supply

MODEL	HEP-2300-55 □□			
OUTPUT	DC VOLTAGE (factory default)	55V		
	CURRENT (factory default)	41.8A		
	RATED CURRENT (max.)	48A		
	POWER (factory default)	2300W		
	RATED POWER (max.)	2304W		
	FULL POWER VOLTAGE RANGE	48 ~ 57.6V		
	RIPPLE & NOISE (max.) Note.2	480mVp-p		
	VOLTAGE ADJ. RANGE	By potentiometer VR 39 ~ 57.6V		
	VOLTAGE TOLERANCE Note.4	± 1.0%		
	LINE REGULATION	± 0.5%		
	LOAD REGULATION	± 0.5%		
	SETUP, RISE TIME	1800ms, 100ms/230VAC at full load		
	HOLD UP TIME (Typ.)	12ms/230VAC at full load		
INPUT	VOLTAGE RANGE Note.5	90 ~ 305VAC	250 ~ 431VDC	
	FREQUENCY RANGE	47 ~ 63Hz		
	POWER FACTOR (Typ.)	PF>0.99/115VAC, PF>0.95/230VAC, PF>0.93/277VAC at full load		
	EFFICIENCY (Typ.)	95.5%		
	AC CURRENT (Typ.)	13.3A / 115VAC	11A / 230VAC	9.3A / 277VAC
	INRUSH CURRENT (Typ.)	Cold start 60A/230VAC		
	LEAKAGE CURRENT	<1.8mA Peak / 240VAC	<2mA Peak / 277VAC	
PROTECTION	OVERLOAD	105 ~ 115% rated output power Protection type : Constant current limiting, unit will shutdown after 5 sec. re-power on to recover		
	OVER VOLTAGE	59 ~ 69.1V Protection type : Shut down O/P voltage, re-power on to recover		
	OVER TEMPERATURE	Shut down O/P voltage, recovers automatically after temperature goes down		
FUNCTION	OUTPUT VOLTAGE PROGRAMMABLE(PV)Note.7	Adjustment of output voltage is allowable to 50 ~ 120% of nominal output voltage Please refer to the Function Manual		
	OUTPUT CURRENT PROGRAMMABLE(PC)Note.7	Adjustment of constant current level is allowable to 20 ~ 100% of rated current Please refer to the Function Manual		
	REMOTE ON/OFF CONTROL	Power ON : Short circuit Power OFF : Open circuit		
	AUXILIARY POWER	12V@0.5A tolerance±10%, ripple 150mVp-p		
	DC-OK SIGNAL	The TTL signal out, PSU turn on = 4.5 ~ 5.5V ; PSU turn off = -0.5 ~ 0.5V. Please refer to the Function Manual		
ENVIRON- MENT	WORKING TEMP.	-40 ~ +70°C (Refer to "Derating Curve")		
	WORKING HUMIDITY	20 ~ 95% RH non-condensing		
	STORAGE TEMP., HUMIDITY	-40 ~ +85°C, 10 ~ 95% RH non-condensing		
	TEMP. COEFFICIENT	±0.03%/°C (0 ~ 50°C)		
VIBRATION	20 ~ 500Hz, 10G 12min./1cycle, period for 72min. each along X, Y, Z axes			

HEP-2300-55 series-Charger

MODEL	HEP-2300-55 □□			
OUTPUT	BOOST CHARGE VOLTAGE Vboost	57.6V		
	FLOAT CHARGE VOLTAGE Vfloat	55.2V		
	RECOMMENDED BATTERY CAPACITY(AMP HOURS)(Note.3)	120 ~ 400AH		
	BATTERY TYPE	Open & Sealed Lead Acid		
	OUTPUT CURRENT (max.)	40A		
INPUT	VOLTAGE RANGE <small>Note.5</small>	90 ~ 305VAC	250 ~ 431VDC	
	FREQUENCY RANGE	47 ~ 63Hz		
	POWER FACTOR (Typ.)	PF>0.99/115VAC, PF>0.95/230VAC, PF>0.93/277VAC at full load		
	EFFICIENCY (Typ.)	95.5%		
	AC CURRENT (Typ.)	13.3A / 115VAC	11A / 230VAC	9.3A / 277VAC
	INRUSH CURRENT (Typ.)	Cold start 60A/230VAC		
	LEAKAGE CURRENT	<1.8mA Peak / 240VAC	<2mA Peak / 277VAC	
PROTECTION	SHORT CIRCUIT	Constant current limiting, unit will shutdown after 5 sec, re-power on to recover.		
	OVER VOLTAGE	59 ~ 69.1V Protection type :Shut down O/P voltage,re-power on to recover		
	OVER TEMPERATURE	Shut down O/P voltage, recovers automatically after temperature goes down		
FUNCTION	REMOTE ON/OFF CONTROL	Power ON : Short circuit Power OFF : Open circuit		
	AUXILIARY POWER	12V@0.5A tolerance±10%, ripple 150mVp-p		
	DC-OK SIGNAL	The TTL signal out, PSU turn on = 4.5 ~ 5.5V ; PSU turn off = -0.5 ~ 0.5V. Please refer to the Function Manual		
ENVIRONMENT	WORKING TEMP.	-40 ~ +70°C (Refer to "Derating Curve")		
	WORKING HUMIDITY	20 ~ 95% RH non-condensing		
	STORAGE TEMP., HUMIDITY	-40 ~ +80°C, 10 ~ 95% RH non-condensing		
	TEMP. COEFFICIENT	±0.03%/°C (0 ~ 50°C)		
	VIBRATION	20 ~ 500Hz, 10G 12min./1cycle, period for 72min. each along X, Y, Z axes		

HEP-2300-115/230/380 series-Switching Power Supply

MODEL	HEP-2300-115	HEP-2300-230	HEP-2300-380	
OUTPUT	DC VOLTAGE (factory default)	115V	230V	380V
	CURRENT (factory default)	20A	10A	6.05A
	RATED CURRENT (max.)	20A	10.6A	6.9A
	RATED POWER (max.)	2300W	2300W	2300W
	FULL POWER VOLTAGE RANGE	115 ~ 138V	216 ~ 260V	334 ~ 400V
	RIPPLE & NOISE (max.) <small>Note.2</small>	1500mVp-p	1500mVp-p	4000mVp-p
	VOLTAGE ADJ. RANGE	By potentiometer VR		
		90 ~ 138V	170 ~ 260V	260 ~ 400V
	VOLTAGE TOLERANCE <small>Note.4</small>	±1.0%	±1.0%	±1.0%
	LINE REGULATION	±0.5%	±0.5%	±0.5%
	LOAD REGULATION	±0.5%	±0.5%	±0.5%
SETUP, RISE TIME	1800ms, 100ms/230VAC at full load			
HOLD UP TIME (Typ.)	12ms/230VAC at full load			
INPUT	VOLTAGE RANGE <small>Note.5</small>	90 ~ 305VAC	250 ~ 431VDC	
	FREQUENCY RANGE	47 ~ 63Hz		
	POWER FACTOR (Typ.)	PF>0.99/115VAC, PF>0.95/230VAC, PF>0.93/277VAC at full load		
	EFFICIENCY (Typ.)	95%	95.5%	95.5%
	AC CURRENT (Typ.)	13.3A / 115VAC	11A / 230VAC	9.3A / 277VAC
	INRUSH CURRENT (Typ.)	Cold start 60A/230VAC		
LEAKAGE CURRENT	<1.8mA Peak / 240VAC	<2mA Peak / 277VAC		
PROTECTION	OVERLOAD	105 ~ 115% rated output power Protection type : Constant current limiting, unit will shutdown after 5 sec. re-power on to recover		
	OVER VOLTAGE	145 ~ 166V	273 ~ 312V	420 ~ 480V
	OVER TEMPERATURE	Shut down O/P voltage, recovers automatically after temperature goes down		
FUNCTION	OUTPUT VOLTAGE PROGRAMMABLE(PV) <small>Note.7</small>	Adjustment of output voltage is allowable to 50 ~ 120% of nominal output voltage Please refer to the Function Manual		
	OUTPUT CURRENT PROGRAMMABLE(PC) <small>Note.7</small>	Adjustment of constant current level is allowable to 20 ~ 100% of rated current Please refer to the Function Manual		
	REMOTE ON/OFF CONTROL	Power ON : Short circuit Power OFF : Open circuit		
	AUXILIARY POWER	12V@0.5A tolerance±10%, ripple 150mVp-p		
	DC-OK SIGNAL	The TTL signal out, PSU turn on = 4.5 ~ 5.5V ; PSU turn off = -0.5 ~ 0.5V. Please refer to the Function Manual		
ENVIRONMENT	WORKING TEMP.	-40 ~ +70°C (Refer to "Derating Curve")		
	WORKING HUMIDITY	20 ~ 95% RH non-condensing		
	STORAGE TEMP., HUMIDITY	-40 ~ +85°C, 10 ~ 95% RH non-condensing		
	TEMP. COEFFICIENT	±0.03%/°C (0 ~ 50°C)		
	VIBRATION	20 ~ 500Hz, 10G 12min./1cycle, period for 72min. each along X, Y, Z axes		

SAFETY & EMC (Note.9)	SAFETY STANDARDS	UL62368-1, TUV BS EN/EN62368-1, EAC TP TC 004 approved; design refers to BS EN/EN61558-1, BS EN/EN60335-1 (by request)		
	WITHSTAND VOLTAGE Note.7	OVC III I/P-O/P: 6KVDC I/P-FG: 4KVDC O/P-FG: 4KVDC		
	ISOLATION RESISTANCE Note.7	I/P-O/P, I/P-FG, O/P-FG: 100M Ohms/500VDC/25°C / 70%RH		
	EMC EMISSION	Parameter	Standard	Test Level / Note
		Conducted	BS EN/EN55032 (CISPR32)	Class B
		Radiated	BS EN/EN55032 (CISPR32)	Class A
		Harmonic Current	BS EN/EN61000-3-2	Class A
	EMC IMMUNITY	Voltage Flicker	BS EN/EN61000-3-3	-----
		BS EN/EN55024, BS EN/EN61000-6-2		
		Parameter	Standard	Test Level / Note
ESD		BS EN/EN61000-4-2	Level 3, 8kV air; Level 2, 4kV contact	
Radiated		BS EN/EN61000-4-3	Level 3	
EFT / Burst		BS EN/EN61000-4-4	Level 3	
Surge		BS EN/EN61000-6-2	2kV/Line-Line 4kV/Line-Earth	
Conducted		BS EN/EN61000-4-6	Level 3	
Magnetic Field		BS EN/EN61000-4-8	Level 4	
Voltage Dips and Interruptions		BS EN/EN61000-4-11	>95% dip 0.5 periods, 30% dip 25 periods, >95% interruptions 250 periods	
OTHERS	MTBF	478K hrs min. Telcordia SR-332 (Bellcore); 44.8K hrs min. MIL-HDBK-217F (25°C)		
	DIMENSION	375*280*88mm (L*W*H), without mounting plate		
	PACKING	14Kg; 1pcs/14Kg/1.36CUFT		
NOTE	<ol style="list-style-type: none"> All parameters NOT specially mentioned are measured at 230VAC input, rated load and 25°C of ambient temperature. Ripple & noise are measured at 20MHz of bandwidth by using a 12" twisted pair-wire terminated with a 0.1µf & 47µf parallel capacitor. This is Mean Well's suggested range. Please consult your battery manufacturer for their suggestions about maximum charging current limitation. Tolerance includes set up tolerance, line regulation and load regulation. Derating may be needed under low input voltages. Please check the derating curve for more details. SVR function is disabled during PV/PC programming operation. During withstandstandards voltage and isolation resistance testing, the screw "A" shall be temporarily removed, and shall be installed back after the testing. The power supply is considered a component which will be installed into a final equipment. All the EMC tests are been executed by mounting the unit on a 1100mm*650mm metal plate with 1mm of thickness. The final equipment must be re-confirmed that it still meets EMC directives. For guidance on how to perform these EMC tests, please refer to "EMI testing of component power supplies." (as available on https://www.meanwell.com/Upload/PDF/EMI_statement_en.pdf) The ambient temperature derating of 3.5°C/1000m with fanless models and of 5°C/1000m with fan models for operating altitude higher than 2000m(6500ft). This series meets the typical life expectancy of > 55,000 hours of operation when Tcase, particularly (⊙) point (or TMP, per DLC), is about 80°C or less. <p>※ Product Liability Disclaimer : For detailed information, please refer to https://www.meanwell.com/serviceDisclaimer.aspx</p>			

2.4 Derating curve

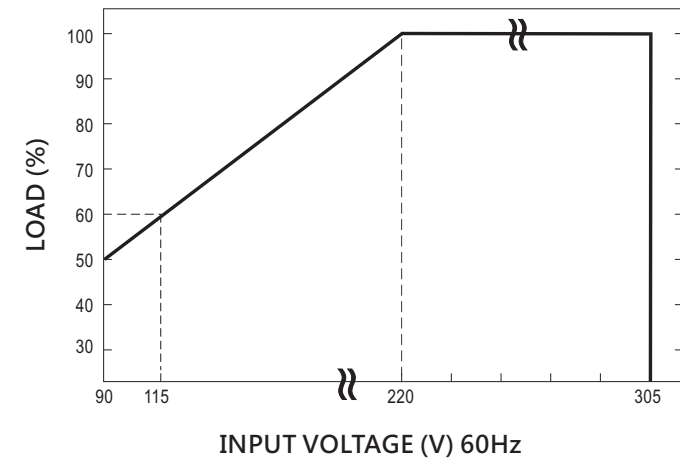
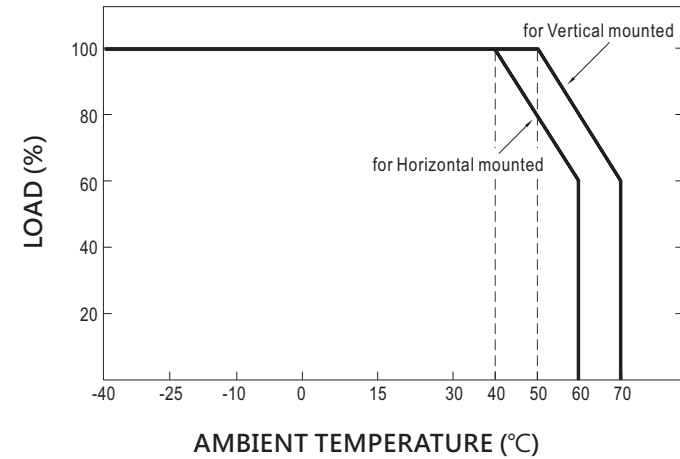



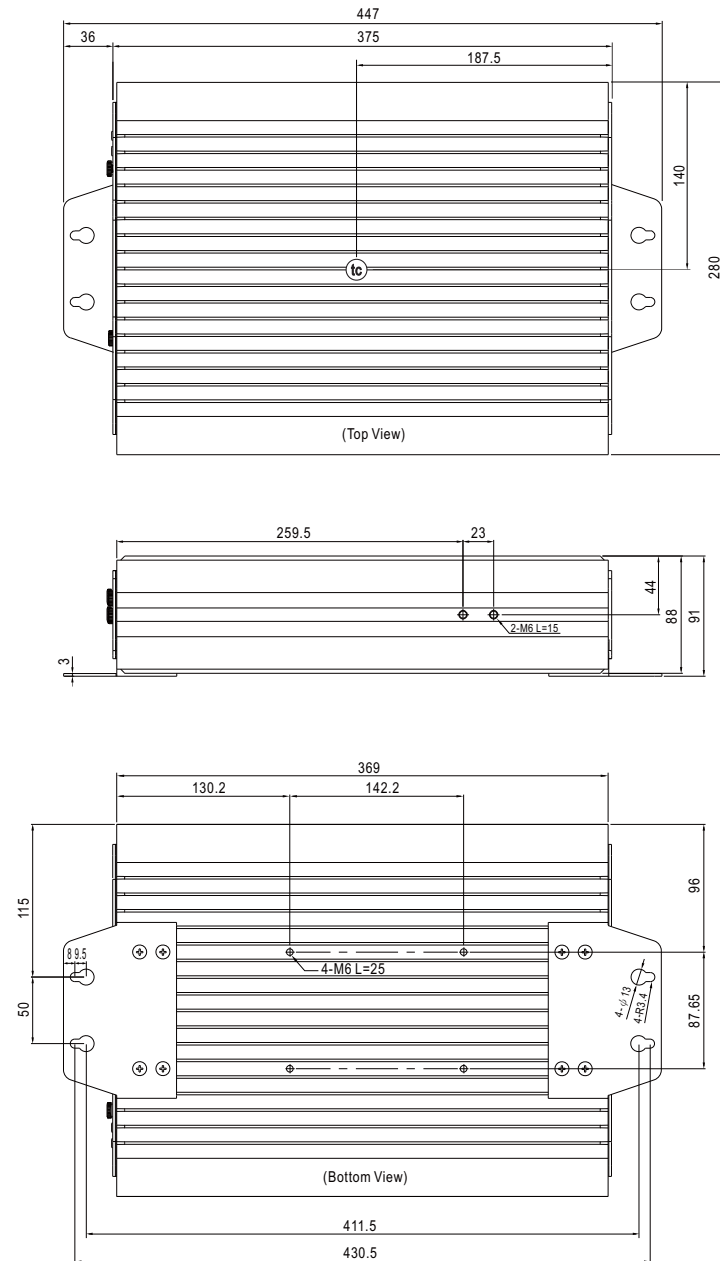



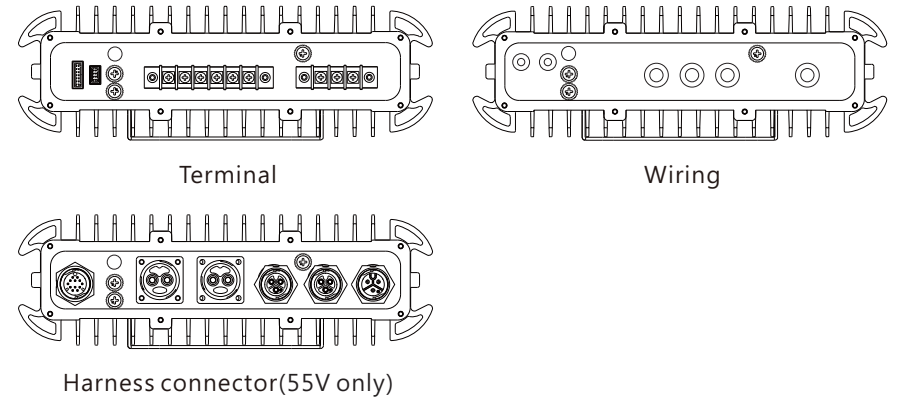

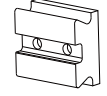

2.5 Mechanical specification

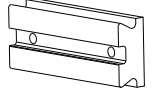

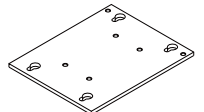
2.6 Output Type

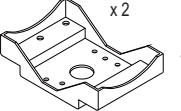

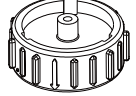
2.7 Accessory List (Optional equipment)

MW's Order No.	Item	Quantity
PGG2BKT-001 (For housing side)	①  +  M6 L=16*2	1
PGG2BKT-002 (For pole side)	②  +  M6 L=16*2	1
PGG2BKT-003	③  +  M6 L=25*4	1
PGG2BKT-004	④  x2 +  M6 L=12*4	1
PFF1ZAHB-A0025(A) (55V only)	⑤  Waterproof connector cap for AC, output 1/2 and alarm signal.	1
PFF1CAP-WACMQMA1(B) (55V only)	⑥  Waterproof connector cap for output 3 and Battery charger.	1

3.Installation & Wiring

3.1 Mounting

3.1.1 Normal Mounting

HEP-2300 can be installed onto a horizontal surface or a vertical wall.

- NOTE: 1. Vertical installation is only suitable for a firm surface with the ability to carry at least 13KG.
2. Mounting orientation other than horizontal and vertical surfaces, please contact Mean Well.

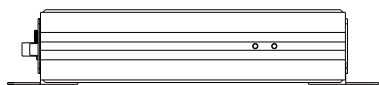

Horizontal mounting

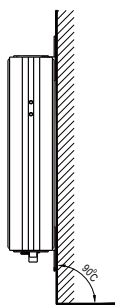

Vertical mounting

3.1.2 Pole Mounting

3.1.2.1 Rear Mounting

①

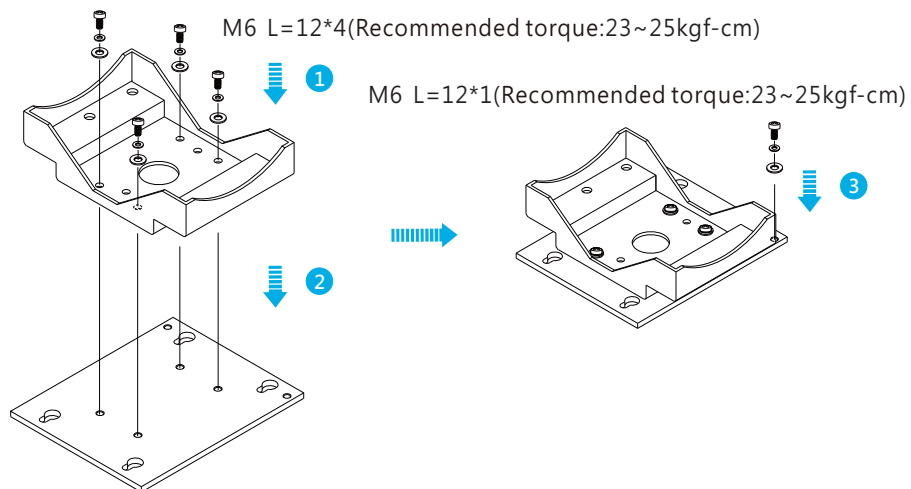

②

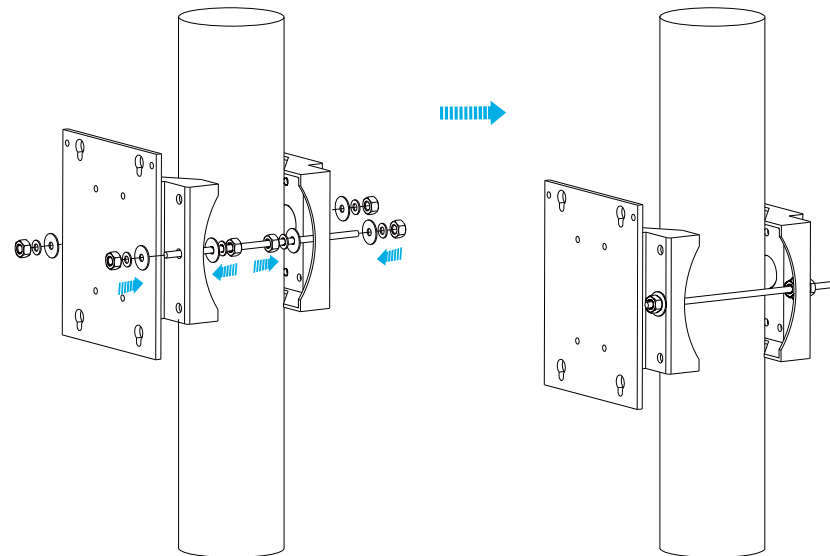

③

M6 L=25*4(Recommended torque:23~25kgf-cm)

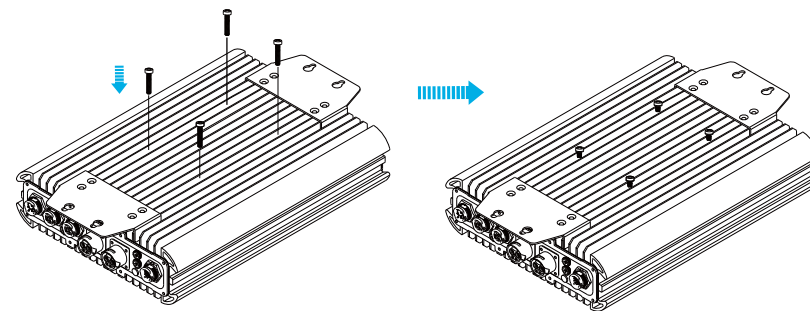

④

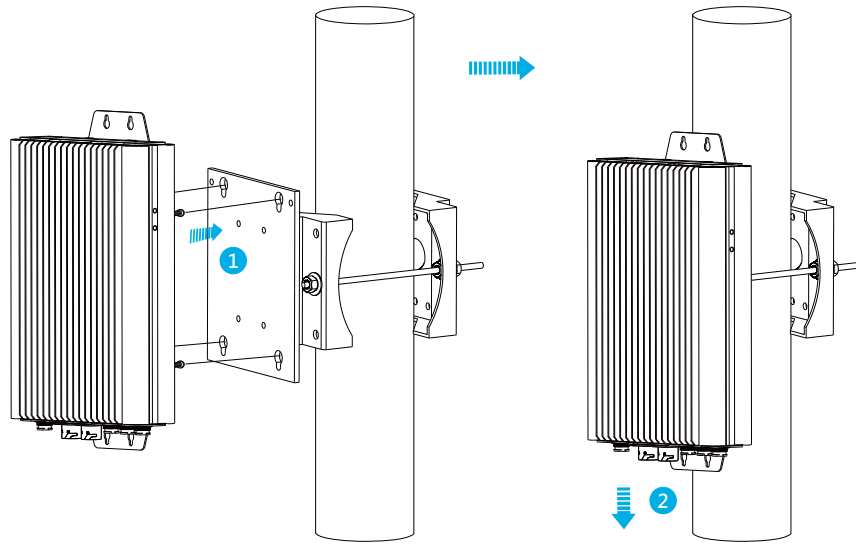

⑤

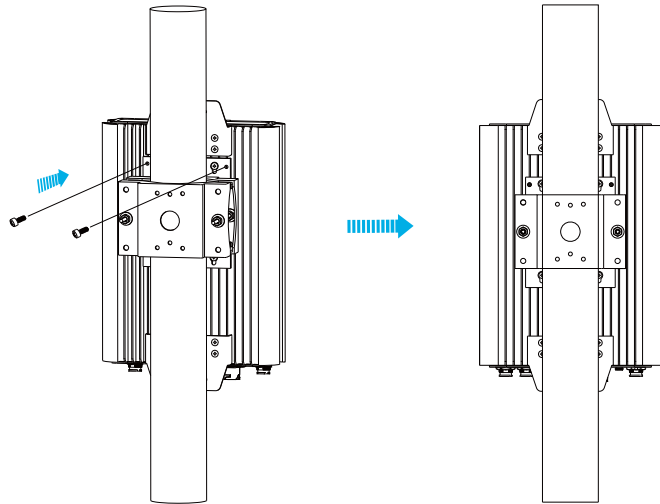

3.1.2.2 Side Mounting

①

M6 L=16*2 (Recommended torque: 23~25kgf-cm)

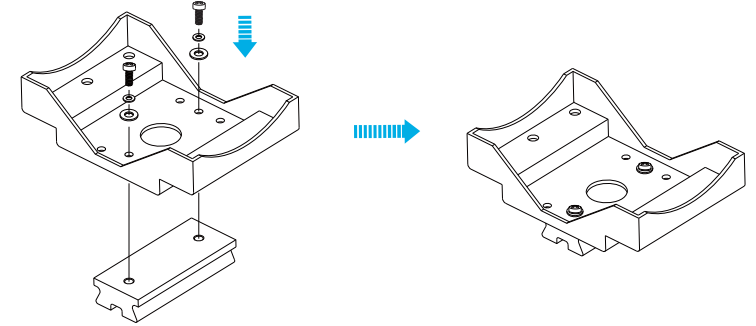

②

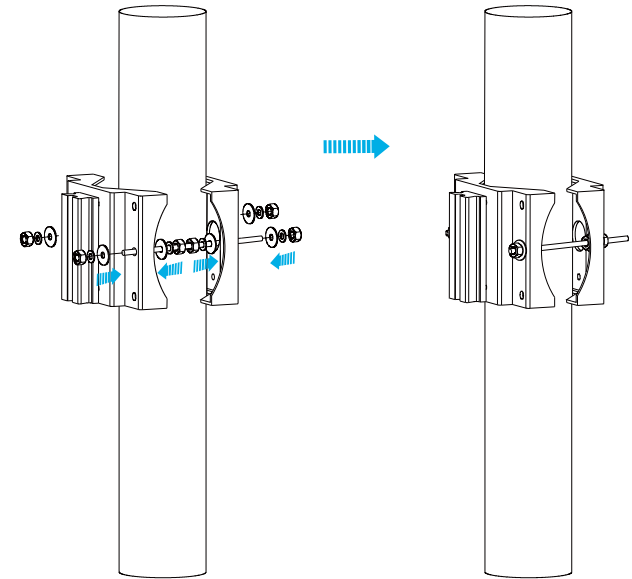

3

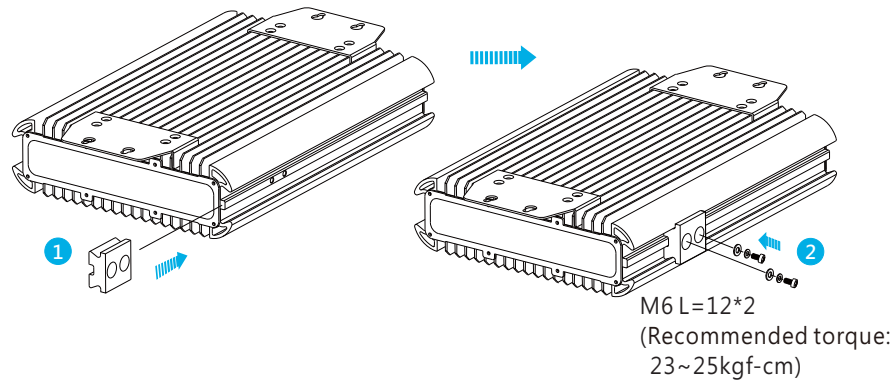

4

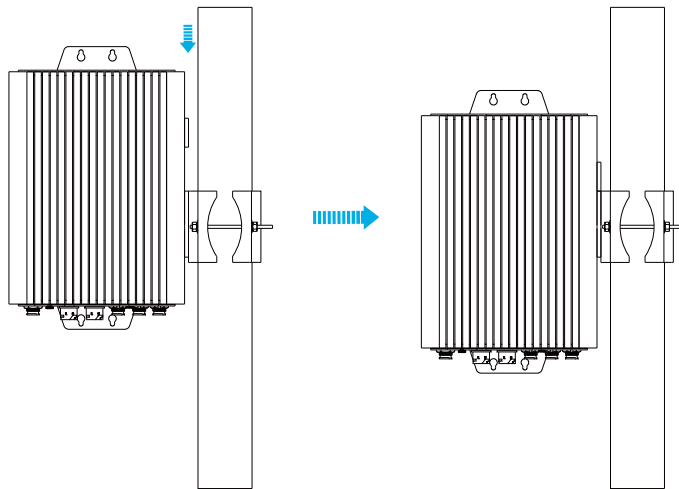

3.2 Wiring

1. Choose the right and suitable cable size for connection between the HEP-2300 and the loads/batteries. Please refer to 3.3 DC cable size selection.
2. Connect the DC positive polarity of the supply to the positive of the loads/batteries and connect the DC negative polarity of the supply to the negative of loads/batteries. Make sure there is no reverse polarity or short-circuit on the connection.

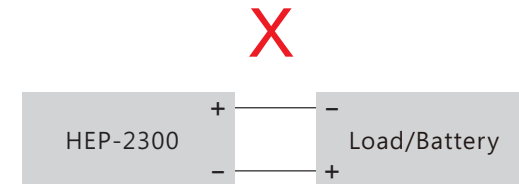
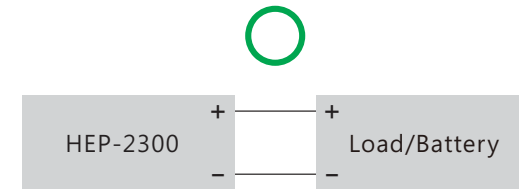

3. Connect the supply to the AC grid, FG to the earth, AC/N to the neutral and AC/L to the live.

3.3 DC Cable Size Selection

Wire connections should be as short as possible and less than 1 meter is highly recommended. Make sure that suitable wires are chosen based on safety requirement and rating of current. Small cross section will result in lower efficiency, less output power and the wires may also become overheated and cause danger. For selection, please refer to table 3-1.

Table 3-1 Wire recommendations

AWG	Cross-section Area(mm ²)	DC current (A)
14	1.5	10A ~ 16A
12	2.5	16A ~ 25A
10	4	25A ~ 32A
8	6	32A ~ 40A
6	10	40A ~ 63A
4	16	63A ~ 80A
2	25	80A ~ 100A

4. Panel and LED indicator

4.1 Terminal

4.1.1 Panel Description

- (A) LED indicator:**
Indicate the status of the supply and load condition.
- (B) SVR:**
For DC voltage setting.
- (C) Address rotary switch:**
For device addressing when communication interface is using.
- (D) Hipot earthing screw:**
Remove the screw for high potential test. After test, tighten the screw to insure the best high potential performance.
- (E) Function pins:**
They are used for control and monitoring functions. Please refer to 4.1.2 and 4.1.3.
- (F) AC input terminals:**
Recommended cable size: 12~22AWG ; Recommended torque: 14 kgf-cm.
- (G) DC output terminals:**
Recommended cable size: 12~22AWG ; Recommended torque: 14 kgf-cm.

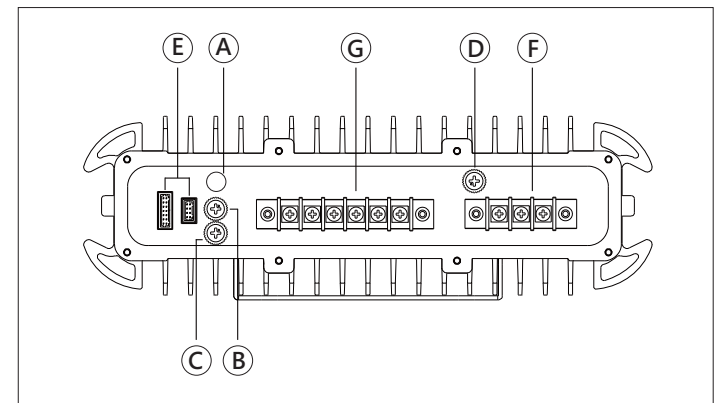

4.1.2 Pin Assignment of CN11

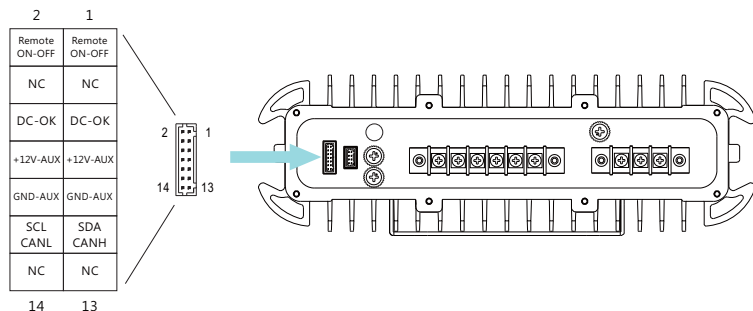

Pin No.	Function	Description
1,2	Remote ON-OFF	The unit can turn the output ON/OFF by dry contact between Remote ON/OFF and +12V-AUX. (Note) Short (10.8 ~ 13.2V) : Power ON ; Open(0 ~ 0.5V) : Power OFF ; The maximum input voltage is 13.2V
3,4,13,14	NC	-----
5,6	DC-OK	Low (-0.5 ~ 0.5V) : When $V_{out} \leq 77\% \pm 6\%$ at power mode. $V_{out} \leq 66\% \pm 6\%$ at charger mode. High (4.4 ~ 5.5V) : When $V_{out} \geq 80\% \pm 6\%$ at power mode. $V_{out} \geq 67\% \pm 6\%$ at charger mode. The maximum sourcing current is 10mA and only for output. (Note)
7,8	+12V-AUX	Auxiliary voltage output, 10.8~13.2V, referenced to GND-AUX (pin9 & 10). The maximum load current is 0.5A. This output is not controlled by "Remote ON-OFF" .
9,10	GND-AUX	Auxiliary voltage output GND. The signal return is isolated from the output terminals (+V & -V).
11	SDA	For PMBus model: Serial Data used in the PMBus interface. (Note)
	CANH	For CANBus model: Data line used in CANBus interface. (Note)
12	SCL	For PMBus model: Serial Clock used in the PMBus interface. (Note)
	CANL	For CANBus model: Data line used in CANBus interface. (Note)

Note: Isolated signal, referenced to GND-AUX.

Mating Housing	JST PHDR-14VS or equivalent
Terminal	JST SPHD-001T-P0.5 or equivalent

4.1.3 Pin Assignment of CN81

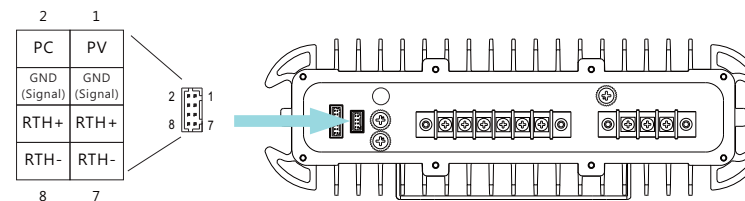

Pin No.	Function	Description
1	PV	Connection for output voltage programming. (Note)
2	PC	Connection for constant current level programming. (Note)
3,4	GND (Signal)	Negative output voltage signal.
5,6	RTH+	Temperature sensor (NTC, 5KOhm) comes along with the charger can be connected to the unit to allow temperature compensation of the charging voltage. (55V only)
7,8	RTH-	

Note: Non-isolated signal, referenced to [GND(signal)].

Mating Housing	JST PHDR-8VS or equivalent
Terminal	JST SPHD-001T-P0.5 or equivalent

4.2 Wiring

4.2.1 Panel Description

- (A) LED Indicator:**
Indicate the status of the supply and load condition.
- (B) SVR:**
For DC voltage setting.
- (C) Address rotary switch:**
For device addressing when communication interface is using.
- (D) Hipot earthing screw:**
Remove the screw for high potential test. After test, tighten the screw to insure the best high potential performance.
- (E) Control cables:**
They are used for control and monitoring functions. Please refer to 4.2.2 and 4.2.3.
- (F) AC input cable:**
14AWGx3C*1 ◦
- (G) DC output cable:**
17AWGx2C*2(115V/230V/380V) ; 17AWGx2C*3(55V) ◦

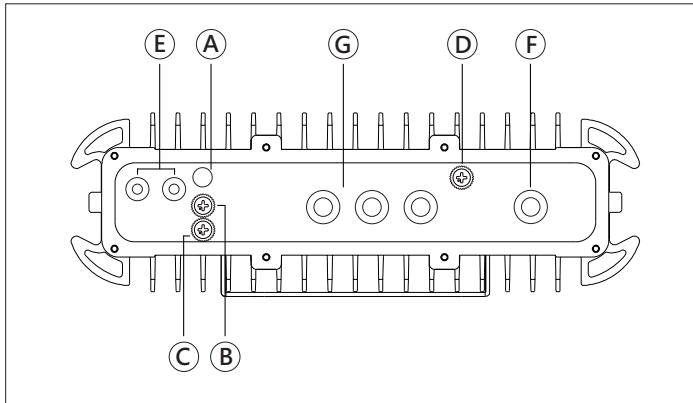

4.2.2 Pin Assignment-Control Wire(1)

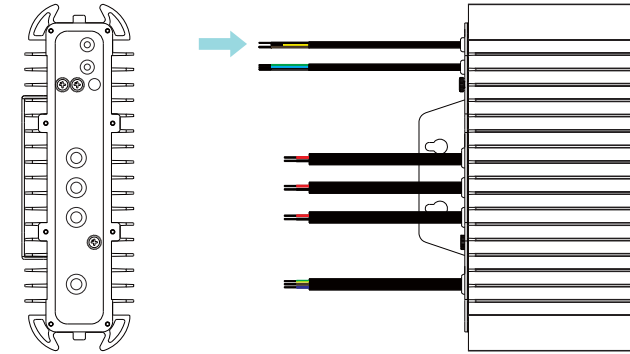

UL2517 22AWG×3C

Color	Function	Description
Brown	DC-OK	Low (0 ~ 0.5V) : When $V_{out} \leq 77\% \pm 6\%$ at power mode. $V_{out} \leq 66\% \pm 6\%$ at charger mode. High (4.4 ~ 5.5V) : When $V_{out} \geq 80\% \pm 6\%$ at power mode. $V_{out} \geq 67\% \pm 6\%$ at charger mode. The maximum sourcing current is 10mA and only for output.(Note.2)
Yellow	+12V-AUX	Auxiliary voltage output, 10.8~13.2V, referenced to GND-AUX. The maximum load current is 0.5A.
Black	GND-AUX	Auxiliary voltage output GND. The signal return is isolated from the output terminals (+V & -V).

Note1: Non-isolated signal, referenced to [GND(signal)].

Note2: Isolated signal, referenced to GND-AUX (GND for CANBus and PMBus protocol).

4.2.3 Pin Assignment-Control Wire(2)

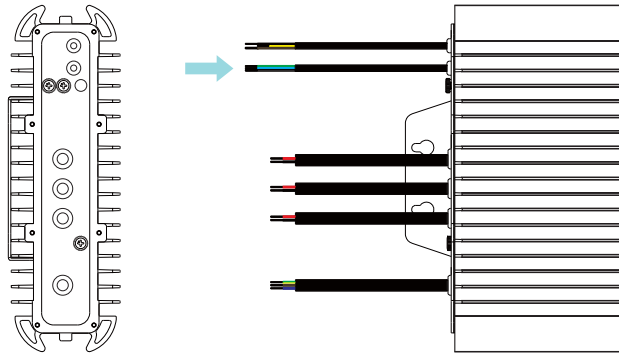

UL2517 22AWG×3C for Blank

Color	Function	Description
Green	PV	Connection for output voltage programming.(Note1)
Blue	PC	Connection for constant current level programming.(Note.1)
White	GND (Signal)	Negative output voltage signal.(PV/PC GND)

UL2517 22AWG×3C for PM/CANBus Function

Color	Function	Description
Green	SDA	For PMBus model: Serial Data used in the PMBus interface. (Note.2)
	CANH	For CANBus model: Data line used in CANBus interface. (Note.2)
Blue	SCL	For PMBus model: Serial Clock used in the PMBus interface. (Note.2)
	CANL	For CANBus model: Data line used in CANBus interface. (Note.2)
White	GND-AUX	Auxiliary voltage output GND. The signal return is isolated from the output terminals (+V & -V).

Note1: Non-isolated signal, referenced to [GND(signal)].

Note2: Isolated signal, referenced to GND-AUX (GND for CANBus and PMBus protocol).

4.3 Harness connector type(55V only)

4.3.1 Panel Description

- Ⓐ **LED Indicator:**
Indicate the status of the supply and load condition.
- Ⓑ **SVR:**
For DC voltage setting.
- Ⓒ **Address rotary switch:**
For device addressing when communication interface is using.
- Ⓓ **Hipot earthing screw:**
Remove the screw for high potential test. After test, tighten the screw to insure the best high potential performance.
- Ⓔ **Control connector:**
It is used for control and monitoring functions. Please refer to 4.3.2.
- Ⓕ **AC input connector**
- Ⓖ **20A DC output connector**
- Ⓗ **50A DC output connector**
- Ⓘ **Battery Back-up connector**

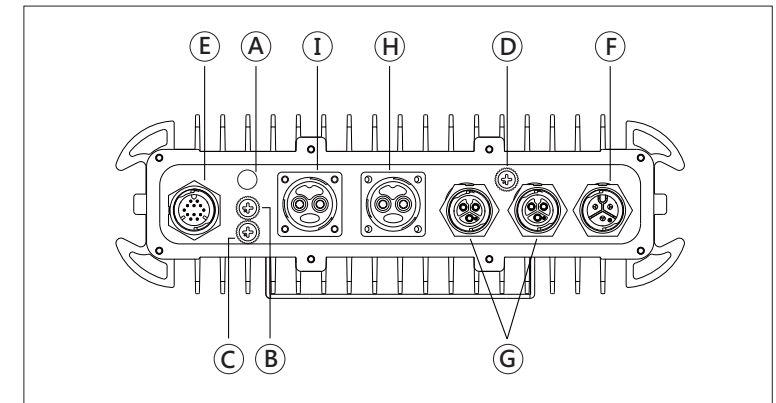

4.3.2 Pin Assignment- Control Connector

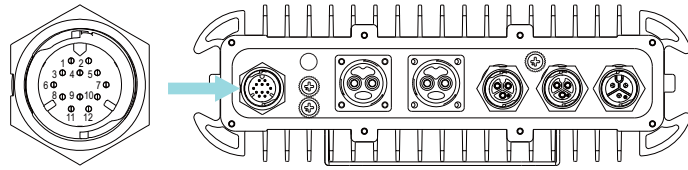

Pin No.	Function	Description
1	DC-OK -GND	Dry contact output. Open: alarm, Closed: normal.
2	Remote ON-OFF	The unit can turn the output OFF by dry contact between OFF and GND-AUX.(Note) Short (10.8 ~ 13.2V) : Power ON ; Open(0 ~ 0.5V) : Power OFF ; The maximum input voltage is 13.2V
3	DC-OK	Dry contact output. Open: alarm, Closed: normal. Relay contact rating(maximum) is 30V/1A resistive.
4	+12V-AUX	Auxiliary voltage output, 10.8~13.2V, referenced to GND-AUX (pin9 & 10). The maximum load current is 0.5A. This output is not controlled by "Remote ON-OFF" .
5,7	GND-AUX	Auxiliary voltage output GND. The signal return is isolated from the output terminals (+V & -V).
6	AC Fail -GND	Dry contact output, Open: alarm; Closed: normal.
8	AC Fail	Dry contact output, Open: alarm; Closed: normal. Relay contact rating(maximum) is 30V/1A resistive. .
9	T-Alarm -GND	Dry contact output, Open: normal; Closed: alarm. (OTP signal)
10	SDA	For PMBus model: Serial Data used in the PMBus interface. (Note)
	CANH	For CANBus model: Data line used in CANBus interface. (Note)
	Data +	For RS-485 model: Data +.
11	T-Alarm	Dry contact output, Open: normal; Closed: alarm. (OTP signal) Relay contact rating(maximum) is 30V/1A resistive.
12	SCL	For PMBus model: Serial Clock used in the PMBus interface. (Note)
	CANL	For CANBus model: Data line used in CANBus interface. (Note)
	Data -	For RS-485 model: Data -.

Note: Isolated signal, referenced to GND-AUX.

4.3.3 Connector Mating

AC Input Pin No, Assignment : ALTW CC-03PMMS-QC800P or equivalent

 Max. 20A	Pin No.	Assignment	Mating connector CC-03BFFA-QL8APP or equivalent
	1	AC/L	
	2	FG	
3	AC/N		

DC Output 1,2 No. Assignment: ALTW CC-03PMFS-QC800P or equivalent

 Max. 20A	Pin No.	Assignment	Mating connector CC-03BFMA-QL8APP or equivalent
	1,3	+V	
	2	-V	

DC Output 3 Battery Back-up Pin No. Assignment: ALTW PWM-02RMFS-TS700 or equivalent

 Max. 50A	Pin No.	Assignment	Mating connector PWM-02BFMB-TL7001 or equivalent
	1	+V	
	2	-V	

4.4 LED Indicator

Power supply mode	
LED Indicator	Status
Green	Normal working
Red	Abnormal (OTP, OLP, etc...)
Red Flashing	The LED will flash with the red light when the internal temperature reaches 95°C; under this condition, the unit still operates normally without entering OTP. (In the meantime, an alarm signal will be sent out through the PMBus/CANBus/Modbus interface.)

Charger mode (55V model only)	
LED Indicator	Status
Green	Floating(stage 3) or fully charged
Orange	Charging(stage 1 or stage 2)
Red	Abnormal (OTP, OLP or charge timeout)
Red Flashing	The LED will flash with the red light when the internal temperature reaches 95°C; under this condition, the unit still operates normally without entering OTP. (In the meantime, an alarm signal will be sent out through the PMBus/CANBus/Modbus interface.)

5. Operation

5.1 Function Difference

	55V							115V/230V/380V					
	Terminal		Wiring			Harness		Terminal		Wiring			
	BLK	PM	BLK	PM	CAN	BLK	PM	MOD	BLK	PM	BLK	PM	CAN
Charger function	■	■		■	■	■	■	■					
PV/PC	■	■	■						■	■	■		
PMBus		■		■			■		■		■		
CANBus	■				■	■			■				■
Modbus RTU								■					
LED indicator	■	■	■	■	■	■	■	■	■	■	■	■	■
Remote ON/OFF	■	■				■	■	■	■	■			
Temperature compensation	■	■											
12V/0.5A AUX	■	■	■	■	■	■	■	■	■	■	■	■	■
DC-OK signal	■	■	■	■	■	■	■	■	■	■	■	■	■
AC-Fail signal						■	■	■					
OTP signal						■	■	■					

5.2 Application Examples of Different Output Forms

5.2.1 Terminal and wiring

Terminal and wiring types are suitable for power supply and charger applications in harsh environment. Factory setting is at power supply mode. For charger mode, please refer to 5.10.

NOTE: Only 55V model has charger mode

5.2.2 Harness connector (only 55V model)

Harness connector type is suitable for cell site applications. There are three outputs with different current capacity at DC end, which can be connected to antennae with different power rating, such as 3G -5G. In addition, the DC end also supports battery back-up input so that the HEP-2300 can continue operating without interruption even if the grid power is lost, improving the reliability of the system.

NOTE: a. The three DC outputs are connected together internally, so, one of them in over current condition will cause the whole unit shutting down. It is suggested to add current limiting equipment at each output to prevent system fail.

b. Please set the unit at charger mode when battery back-up is connected. Please refer to 5.10.

c. Please make sure the battery back-up is within the voltage range of the system before connecting.

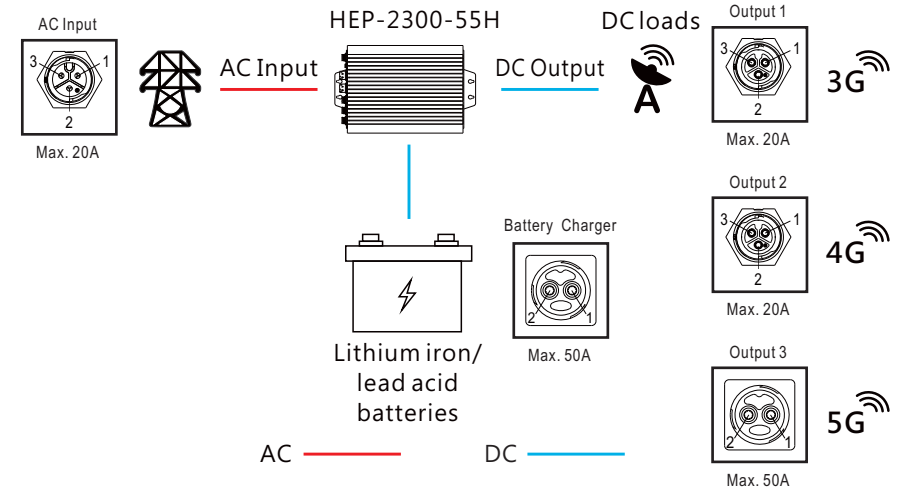

5.3 Inrush Current Limiting

- Built-in AC inrush current limiting circuit.
- Since the inrush current limiting circuit mainly consists of a NTC thermistor and a relay, inrush current will be much higher than the specified value if the thermistor in AC side is not allowed sufficient time to cool down. After turning off the supply, a 10 second cool down period is recommended before turning on again.

5.4 Power Factor Correction (PFC)

- Built-in active power factor correction (PFC) function, power factor (PF) will be 0.95 or better at full load condition. PF will be less than 0.95 if it is not at full load condition.

5.5 Output Voltage Adjustment

- Output voltage can be adjusted via SVR, PV or communication interface.

5.5.1 SVR

Output voltage can be adjusted via the SVR of the panel. Please refer to the diagram below for the location. After voltage setting, please reinstall the waterproof plug back to ensure waterproof performance.

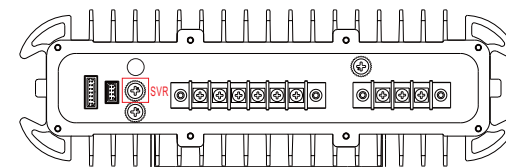

Figure 5-1

5.5.2 PV (Output Voltage Programming)

1. Connect output of the external DC source to PV and GND-signal, as shown in Figure 5-2. For detailed pin assignment of each type, please refer to chapter 4.
2. Relationship between output voltage and external DC source is shown in Figure 5-3.
3. When increasing the output to a higher voltage level, please reduce the loading current accordingly. Output wattage of the unit should not exceed the rated value under any circumstance.

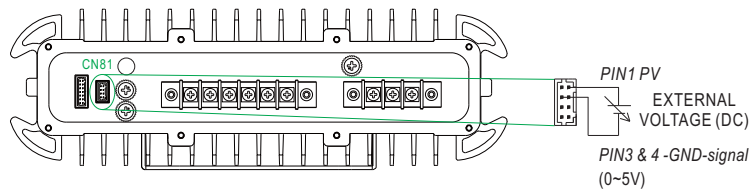

Figure 5-2

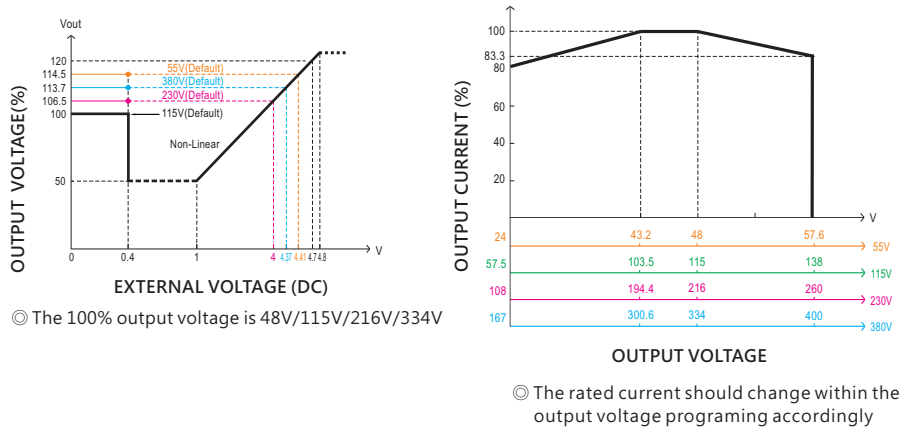

Figure 5-3

5.5.3 Communication

Output voltage can be adjusted through communication interfaces: PMBus, CAN bus or Modbus. Please refer to chapter 6 for detailed information.

5.6 Output Current Adjustment

- Output current can be adjusted via PC and communication interface.

5.6.1 PC (Output Current Programming)

1. Connect output of the external DC source to PC and GND-signal, as shown in Figure 5-4. For detailed pin assignment of each type, please refer to chapter 4.
2. Relationship between output current and external DC source is shown in Figure 5-5

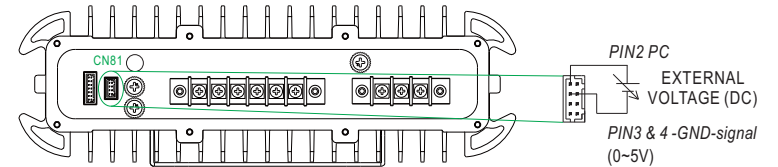

Figure 5-4

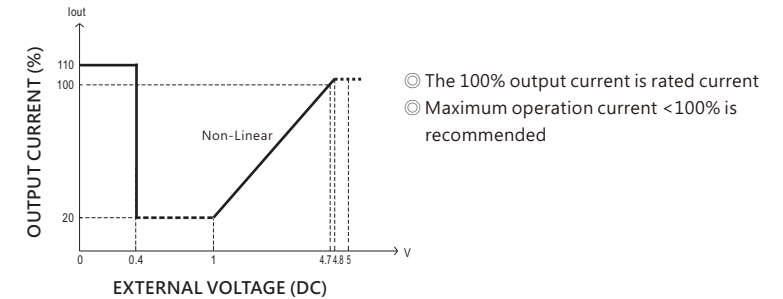

Figure 5-5

5.6.2 Communication

Output current can be adjusted through communication interfaces: PMBus, CAN bus or Modbus. Please refer to chapter 6 for detail.

5.7 Remote Control

- Built-in remote ON/OFF control circuit, which is used to turn on/off the unit.
- Maximum input voltage 13.2V.

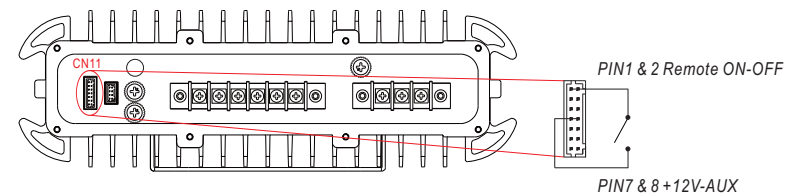

Figure 5-6

Remote ON-OFF to +12V-AUX	Condition
Short	ON
Open	OFF

5.8 DC-OK Signal

- Built-in DC output voltage detection circuit.
- Maximum output current 10mA.

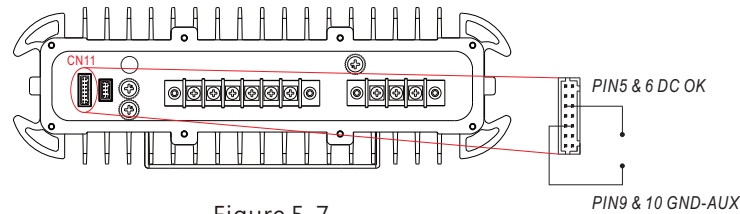

Figure 5-7

DC-OK to GND-AUX	Condition
4.5 – 5.5V	DC OK
-0.5 – 2.5V	Abnormal DC

5.9 Auxiliary Output

- Built-in 12V/0.5A auxiliary output.

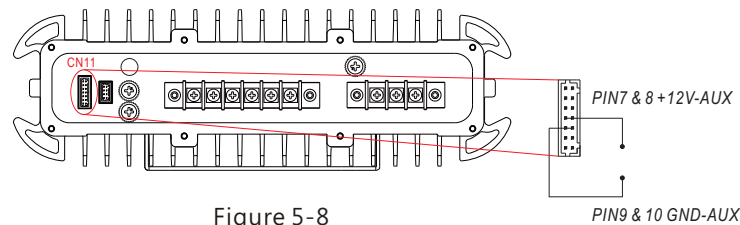

Figure 5-8

+12V-AUX to GND-AUX	12Vdc
---------------------	-------

5.10 Charging (Only 55V model has built-in charging function, the other models with higher output voltage need to cooperate with BMS for charging)

- HEP-2300 adopts both 2 and 3 stage charging curves for selection. 2 stage is for easy and fast charging. 3 stage will go into float mode after the battery is fully charged. Users can choose between 2 or 3 stage according to the demand.

5.10.1 2 stage charging

In the initial stage of charging, the charger charges the battery with the maximum current. After a period of time (depending on the battery capacity), the charging current decreases gradually. When the charging current drops to 10% of the rated current, LED indicator lights up in green, indicating that the charging process is complete.

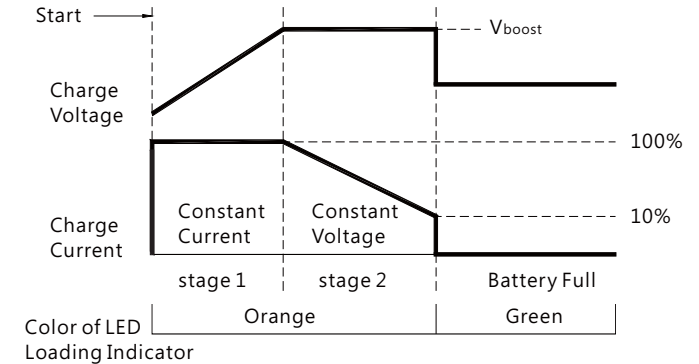

State	HEP-2300-55
Constant Current	40A
Vboost	57.6V

Explanation of 2 stage charging curve

- ① Initial stage (battery analysis) :
Charger will detect and determine whether the battery is properly connected or it is already fully charged.
 - ② Stage 1 (Constant current) :
Maximum constant current is applied for fast charging, until the voltage of battery reaches to boost voltage.
 - ③ Stage 2 (Constant voltage) :
In this stage, charger applies a constant voltage on the battery. Charging current decreases gradually and then shuts down when charging current drops to 10% of rated current.
- * Suitable for lead-acid batteries, such as flooded water type, Gel colloid type, AGM adsorption glass fiber, and lithium batteries, such as lithium-iron, lithium-manganese, ternary lithium.

5.10.2.3 stage charging (default)

In the initial stage of charging, the charger charges the battery with the maximum current. After a period of time (depending on the battery capacity), the charging current decreases gradually. When the charging current drops to 10% of the rated current, LED indicator lights up in green, indicating that the charging process is completed and the charger remains at float charging stage.

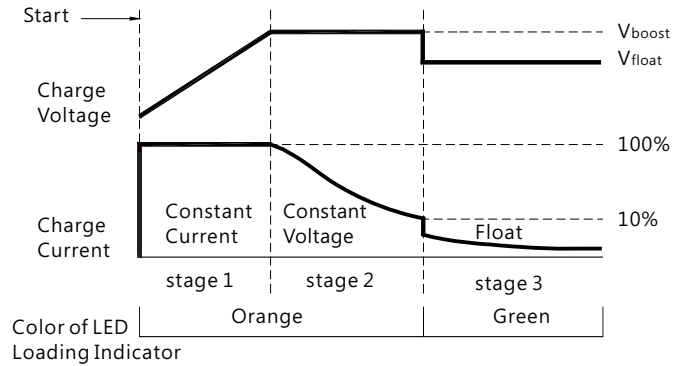

State	HEP-2300-55
Constant Current	40A
V _{boost}	57.6V
V _{float}	55.2V

Explanation of 3 stage charging curve

- ① Initial stage (battery analysis) :
Charger will detect and determine whether the battery is properly connected or it is already fully charged.
 - ② Stage 1 (Constant current) :
Maximum constant current is applied for fast charging, until the voltage of battery reaches to boost voltage.
 - ③ Stage 2 (Constant voltage) :
In this stage, charger applies a constant voltage on the battery. Charging current decreases gradually and then goes into the final stage when charging current drops to 10% of rated current.
 - ④ Stage 3 (float charging) :
The charger is able to provide a float voltage after 2 stage charging in order to keep the battery fully charged at all times. Especially suitable for lead-acid batteries.
- * Suitable for lead-acid batteries (flooded water type, Gel colloid type, AGM adsorption glass fiber).

5.10.3 Temperature Compensation

- The battery temperature sensor (a NTC) that comes with the product can be connected to the battery for sensing temperature of the battery. The charge is able to work normally without the sensor.
- The temperature sensor which comes with the product can be connected to pin Rth+ and pin Rth-. The wire length of the sensor can be adjusted according to different applications by linking the connector and sensor parts with wire length needed. Default setting is -3mV/Cell/, °C compensated voltages are shown as below:

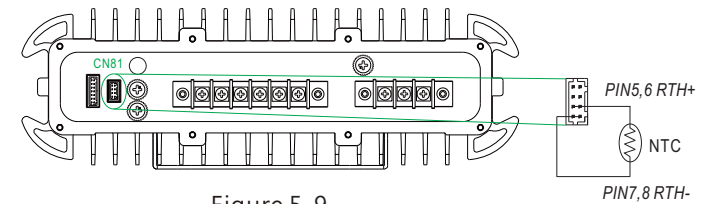

Figure 5-9

Upper limit of voltage compensation	Lower limit of voltage compensation	Compensation range of Temperature
57.6V	49.8V	-30~70°C

NOTE: If the desired parameter differs from the factory setting, SBP-001 or communication interfaces shall be used to change the parameter.

5.10.4 Charge mode setting – via communication interfaces

Users can set the unit at power supply mode or charger mode directly through command: CURVE_CONGIH (PMBus:0xB4h; CANBus/Modbus:0x00B4). Command" CURVE_CONFIG also can be used to set the unit at 2 stage or 3 stage charge and relevant charge settings. Please refer to 5.11 communication interfaces for detailed information.

5.10.5 Charge mode setting – via SBP-001

SBP-001, the smart battery charging programmer developed by MEAN WELL, can be used to set charging curves of the unit through editing software. SBP-001 provides functions such as charging curve adjustment and battery temperature compensation. Install configuration and software interface are shown as below. Please refer to "SBP-001 Smart Battery Charging Programmer User Manual" for details.

<https://www.meanwell.com/webapp/product/search.aspx?prod=SBP-001&pdf=U0JQLUucGRm&a=4>

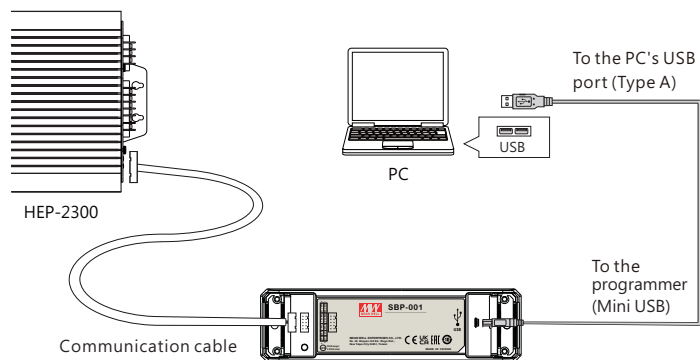

NOTE: SBP-001 does not support Modbus models

User Interface :

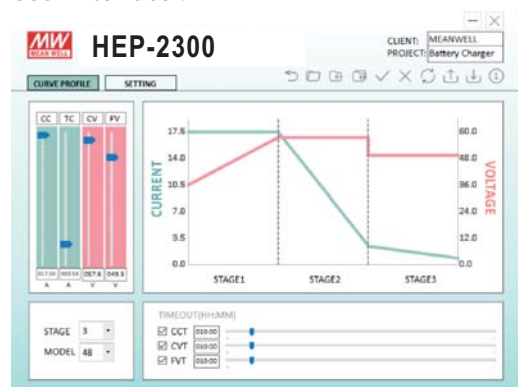

5.11 Factory Resetting

- Users can follow the steps below to restore factory settings for commands: VOUT_TRIM(VOUT_SET), IOUT_OC_FAULT_LIMIT(IOUT_SET), OPERATION, SYSTEM_CONFIG and all charge commands
 - Set the rotary switch at position 1.
 - Turn on the AC without remote on, there should be no voltage at the output.
 - Within 15 seconds, rotate the switch from position 1 to position 4 and then back to position 1.
 - The green LED flashing 3 times means the process is successfully done.
 - Restart the supply to load factory settings.

6.Communication Protocol

- There are two means to control the unit, analog signals and digital communication. Analog is the default setting for the unit, signals including PV, PC and SVR can be used immediately once receiving the unit. The digital communication (PMBus, CAN bus or Modbus) is initially uncontrollable but readable. To activate the adjustment commands of OPERATRION, VOUT_TRIM or VOUT_SET., ect., set PM_CTRL/CAN_CTRL/MOD_CTRL of SYSTEM_CONFIG (PMBus: BEh; CAN bus: 0x00C2; MOD bus: 0x00C4) at "1" and then reboot the unit. Once the digital communication dominates the unit, the analog signals become invalid.

6.1 PMBus Communication Interface

- HEP-2300 is compliant with PMBus Rev.1.1, the maximum communication speed is 100KHz and has the capability of identifying up to 4 addressed units.
- PMBus communication interface is able to provide the current operating status and information. Supported information is as below:
 - Output voltage, current and internal temperature
 - Alarm and status.
 - Manufacturer and mode data.
 - Enabling/disabling of charger mode and Read/wire on charge curve settings.

6.1.1 PMBus Device Addressing

Each HEP-2300 unit should have their unique and own device address to communicate over the PMBus. 7-bit address setting is used to assign advice address, shown in the description below

MSB					LSB	
1	0	0	0	0	A1	A0

A0-A1 allow users to designate an address for the HEP-2300 unit, these two bits are defined through a rotary switch on the side case. There are up to 4 different addresses are available to be assigned. Please refer to Table 6-1 for the detailed setup advice.

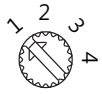

Device No.	Position of switch	Device address	
		A0	A1
0	1	0	0
1	2	1	0
2	3	0	1
3	4	1	1

Table 6-1

6.1.2 PMBus Command List

©The command list of the HEP-2300 is shown in Table 6-2. It is compliant with the standard protocol of PMBus Rev. 1.1. For detailed information, please refer to PMBus official website (<http://pmbus.org/specs.html>).

Table 6-2

Command Code	Command Name	Transaction Type	# of data Bytes	Description
01h	OPERATION	R/W Byte	1	Remote ON/OFF control
02h	ON_OFF_CONFIG	Read Byte	1	ON/OFF function configuration
19h	CAPABILITY	Read Byte	1	Capabilities of a PMBus device
20h	VOUT_MODE	R Byte	1	Define data format for output voltage 55V: format: linear, N= -9 115/230/380V: format: linear, N= -7
21h	VOUT_COMMAND	R Word	2	Define data format for output voltage 55V: format: linear, N= -9 115/230/380V: format: linear, N= -7
22h	VOUT_TRIM*	R/W Word	2	Define data format for output voltage 55V: format: linear, N= -9 115/230/380V: format: linear, N= -7
46h	IOUT_OC_FAULT_LIMIT*	R/W Word	2	Output overcurrent setting value 55V: format: linear, N= -9 115/230/380V: format: linear, N= -7
47h	IOUT_OC_FAULT_RESPONSE	R Byte	1	Define protection and response when an output overcurrent fault occurred
79h	STATUS_WORD	R Word	2	Summary status reporting
7Ah	STATUS_VOUT	R Byte	1	Output voltage status reporting
7Bh	STATUS_IOUT	R Byte	1	Output current status reporting
7Ch	STATUS_INPUT	R Byte	1	AC input voltage status reporting
7Dh	STATUS_TEMPERATURE	R Byte	1	Temperature status reporting
7Eh	STATUS_CML	R Byte	1	Communication, logic, Memory status reporting
80h	STATUS_MFR_SPECIFIC	R Byte	1	Manufacture specific status reporting
88h	READ_VIN	R Word	2	AC input voltage reading value (format: Linear, N=-1)
8Bh	READ_VOUT	R Word	2	Output voltage reading value 55V: format: linear, N= -9 115/230/380V: format: linear, N= -7
8Ch	READ_IOUT	R Word	2	Output current reading value 55V: format: linear, N= -4 115/230/380V: format: linear, N= -5
8Dh	READ_TEMPERATURE_1	R Word	2	Temperature 1 reading value (format: Linear, N= -3)
98h	PMBUS_REVISION	R Byte	1	The compliant revision of the PMBus (default: 11h for Rev. 1.1)
99h	MFR_ID	Block Read	12	Manufacturer's name
9Ah	MFR_MODEL	Block Read	12	Manufacturer's model name
9Bh	MFR_REVISION	Block Read	24	Firmware revision
9Ch	MFR_LOCATION	Block Read	3	Manufacturer's factory location
9Dh	MFR_DATE	Block Read	6	Manufacture date, (format: YYMMDD)
9Eh	MFR_SERIAL	Block Read	12	Product serial number
B0h	CURVE_CC*	R/W Word	2	Constant current setting value of charging curve format: linear, N= -4
B1h	CURVE_CV*	R/W Word	2	Constant current setting value of charging curve format: linear, N= -9
B2h	CURVE_FV*	R/W Word	2	Constant current setting value of charging curve format: linear, N= -9
B3h	CURVE_TC*	R/W Word	2	Constant current setting value of charging curve format: linear, N= -4
B4h	CURVE_CONFIG	R/W Word	2	Configuration setting of charging curve
B5h	CURVE_CC_TIMEOUT	R/W Word	2	CC stage timeout setting value of charging curve (format: Linear, N= 0)
B6h	CURVE_CV_TIMEOUT	R/W Word	2	CV stage timeout setting value of charging curve (format: Linear, N= 0)
B7h	CURVE_FLOAT_TIMEOUT	R/W Word	2	Floating timeout setting value of charging curve (format: Linear, N= 0)
B8h	CHG_STATUS	READ Word	2	Charger's status reporting
BEh	SYSTEM_CONFIG	R/W Word	2	System setting
BFh	SYSTEM_STATUS	READ Word	2	System status

Valid when CURVE_CONFIG.CURVE = 1

Note: Setting commands with * at the end support the EEP_OFF and EEP_CONFIG functions. For detailed information on how to enable them, please refer to SYSTEM_CONFIG (BEh).

© Definition of Command B4h CURVE_CONFIG :

	Bit7	Bit6	Bit5	Bit4	Bit3	Bit2	Bit1	Bit0
High byte	-	-	-	-	-	FVTOE	CVTOE	CCTOE
Low byte	CUVE	STGS	-	-	TCS		CUVS	

Low byte

Bit 0:1 CUVS : Charge Curve Selection
 00 = Customized Charge Curve (default)
 01 = Gel Battery
 10 = Flooded Battery
 11 = AGM Battery

Bit 2:3 TCS : Temperature
 00 = disable
 01 = -3 mV/°C/cell (default)
 10 = -4 mV/°C/cell
 11 = -5 mV/°C/cell

Bit 6 STGS : 2/3 Stage Charge Setting
 0 = 3 stage charge (default, CURVE_VBST and CURVE_V FLOAT)
 1 = 2 stage charge (only CURVE_VBST)

Bit 7 CUVE : Charge Curve Function Enable
 0 = disabled, power supply mode (default)
 1 = enabled, charger mode

High byte

Bit 0 CCTOE : Constant Current Stage Timeout Indication Enable
 0 = disabled (default)
 1 = enabled

Bit 1 CVTOE : Constant Voltage Stage Timeout Indication Enable
 0 = disabled (default)
 1 = enabled

Bit 2 FVTOE : Float Voltage Stage Timeout Indication Enable
 0 = disabled (default)
 1 = enabled

© Definition of Command B8h CHG_STATUS :

	Bit7	Bit6	Bit5	Bit4	Bit3	Bit2	Bit1	Bit0
High byte	FVTOF	CVTOF	CCTOF	-	BTNC	NTCER	-	-
Low byte	-	-	-	-	FVM	CVM	CCM	FULLM

Low byte

Bit 0 FULLM : Fully Charged Mode Status
 0 = NOT fully charged
 1 = fully charged

Bit 1 CCM : Constant Current Mode Status
 0 = the charger NOT in constant current mode
 1 = the charger in constant current mode

Bit 2 CVM : Constant Voltage Mode Status
 0 = the charger NOT in constant voltage mode
 1 = the charger in constant voltage mode

Bit 3 FVM : Float Mode Status
 0 = the charger NOT in float mode
 1 = the charger in float mode

High byte

Bit 2 NTCER : Temperature Compensation Status
 0 = NO short-circuit in the circuitry of temperature compensation
 1 = the circuitry of temperature compensation has short-circuited

Bit 3 BTNC : Battery Detection
 0 = battery detected
 1 = No battery detected

Bit 5 CCTOF : Time Out Flag of Constant Current Mode
 0 = NO time out in constant current mode
 1 = constant current mode timed out

Bit 6 CVTOF : Time Out Flag of Constant Voltage Mode
 0 = NO time out in constant voltage mode
 1 = constant voltage mode timed out

Bit 7 FVTOF : Time Out Flag of Float Mode
 0 = NO time out in float mode
 1 = float mode timed out

Note :

NTCER : When Temperature Compensation Short occurs, the output will shut down and the LED indicator will turn red. The charger will automatically restart after the Temperature Compensation Short condition is removed.

BTNC : When there is no battery detected, the charger stops charging the battery and the LED indicator turns red. The charger needs to re-power on to re-start charging the battery.

CCTOF : When timeout arises in the Constant Current stage, the charger stops charging the battery and the LED indicator turns red. The charger needs to re-power on or remote on/off to re-start charging the battery.

CVTOF : When timeout arises in the Constant Voltage stage, the charger stops charging the battery and the LED indicator turns red. The charger needs to re-power on or remote on/off to re-start charging the battery.

FVTOF : When timeout arises in the Float stage, the charger stops charging the battery and the LED indicator turns green. This charging flow is finished; the charger needs to re-power on or remote on/off to start charging a different battery.

©Definition of Command BEh SYSTEM_CONFIG :

	Bit7	Bit6	Bit5	Bit4	Bit3	Bit2	Bit1	Bit0
High byte	-	-	-	-	-	EEP_OFF	EEP_CONFIG	
Low byte	-	-	-	-	-	OPERATION_INIT	PM_CTRL	

Low byte

Bit 0 PM_CTRL PMBus Control Selection

0 = Output voltage and current controlled by SVR/PV/PC (factory default)

1 = Output voltage, current and remote ON/OFF controlled by PMBus (VOUT_TRIM · IOUT_FAULT_LIMIT · OPERATION)

Bit 1: 2 OPERATION_INIT : OPERATION_INIT : Initial Operational Behavior

0b00 = power on with 0x00: OFF

0b01 = power on with 0x80: ON (factory default)

0b10 = power on with the last setting

0b11 = Not used

Note: Unsupported settings display with "0"

High Byte:

Bit 0:1 EEP_CONFIG: EEPROM Configuration

00: Immediate. Changes to parameters are written to EEPROM immediately (factory default)

01: 1 minute delay. Write changes to EEPROM if all parameters remain unchanged for 1 minute

10: 10 minute delay. Write changes to EEPROM if all parameters remain unchanged for 10 minutes

11: Reserved

Bit 2 EEP_OFF: EEPROM storage function ON/OFF

0: Enable. Parameters to be saved into EEPROM (factory default)

1: Disable. Parameters NOT to be saved into EEPROM

©Definition of Command BFh SYSTEM_STATUS :

	Bit7	Bit6	Bit5	Bit4	Bit3	Bit2	Bit1	Bit0
High byte	-	-	-	-	-	-	-	-
Low byte	-	EEPER	INITIAL_STATE	ADL_ON	-	-	DC_OK	-

Low byte

Bit 1: DC_OK : The DC output Status

0 = DC output too low

1 = DC output at a normal range

Bit 4 ADL_ON : Active dummy load Status

0 = Active dummy load NOT activate

1 = Active dummy load activate

Bit 5 INITIAL_STATE : Initial Stage Indication

0 = The unit NOT in an initial state

1 = The unit in an initial state

Note: Unsupported settings display with "0".

Bit 6 EEPER: EEPROM Access Error

0 = EEPROM accessing normally

1 = EEPROM access error

Note:

1.EEPROM: When EEPROM Access Error occurs, the unit stops working and the LED indicator turns red. The unit needs to re-power on to recover after the error condition is removed

2.Unsupported settings display with "0".

6.1.3 Notes on PMBus

1.Insert a at least 50msec delay between commands.

2.Examples for Format Conversion:

(1) LINEAR16 format: VOUT_COMMAND, VOUT_TRIM, READ_VOUT, CURVE_CV and CURVE_FV.

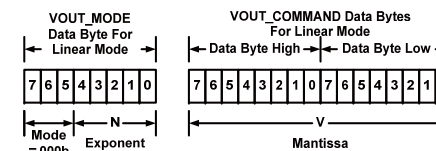

Linear Format Data Bytes

The Mode bits are set to 000b.

The Voltage, in volts, is calculated from the equation:

$$\text{Voltage} = V \cdot 2^N$$

Where:

Voltage is the parameter of interest in volts;

V is a 16 bit unsigned binary integer; and

N is a 5 bit two's complement binary integer.

For example:

V_{o_real} (actual output voltage) = $V \times 2^N$, V is from READ_VOUT.

If VOUT_MODE = 0x17, meaning N is -9. READ_VOUT is 0x3000 → 12288, then $V_{o_real} = 12288 \times 2^{-9} = 24.0V$.

(2)LINEAR11 format: IOUT_OC_FAULT_LIMIT, READ_VIN, READ_IIN, READ_IOUT, READ_TEMPERATURE_1, READ_FAN_SPEED_1, READ_FAN_SPEED_2, CURVE_CC, CURVE_TC, CURVE_CC_TIMEOUT, CURVE_CV_TIMEOUT and CURVE_FV_TIMEOUT.

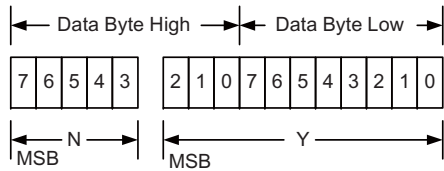

Linear Data Format Data Bytes Y, N and the "real world" value is:

The relation between

$$X = Y \cdot 2^N$$

Where, as described above:

X is the "real world" value;

Y is an 11 bit, two's complement integer; and

N is a 5 bit, two's complement integer.

Devices that use the Linear format must accept and be able to process any value of N.

For example:

I_{o_real} (actual output current) = $Y \times 2^N$, Y is from READ_IOUT.

If READ_IOUT is 0xF188, meaning N is -2 and Y is 0x0188. Y is 0x0188 → 392, then $I_{o_real} = 392 \times 2^{-2} = 98.0A$.

6.2 CANBus Communication Interface

- Physical layer specification

This protocol follows CAN ISO-11898 with Baud rate of 250Kbps.

- Data Frame

This protocol uses Extended CAN 29-bit identifier frame format or CAN 2.0B.

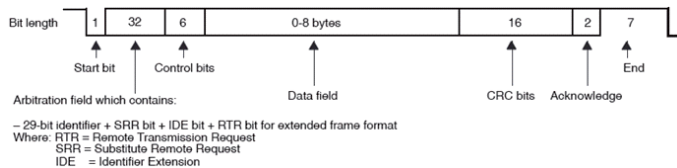

- Communication Timing

Min. request period (Controller to HEP-2300): 50mSec ◦

Max. response time (HEP-2300 to Controller): 12.5mSec ◦

Min. packet margin time (Controller to HEP-2300): 12.5mSec ◦

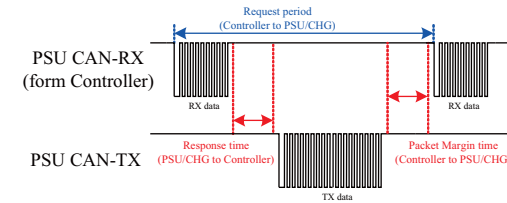

- Data Field Format

Controller to HEP

Write:

Date field bytes

0	1	2	3
COMD. low byte	COMD. high byte	Data low byte	Data high byte

Read:

Date field bytes

0	1
COMD. low byte	COMD. high byte

HEP to Controller

Response:

Date field bytes

0	1	2	7
COMD. low byte	COMD. high byte	Data low 1		Data high 6

NOTE: HEP will not send data back when write parameters, such as VOUT_SET

6.2.1 Message ID definition

Message ID	Description
0x000C00XX	HEP to Controller Message ID
0x000C01XX	Controller to HEP Message ID
0x000C01FF	Controller broadcasts to HEP Message ID

NOTE: XX means the address of HEP-2300 (which can be assigned by the address rotary switch, range from 0x00 ~ 0x03)

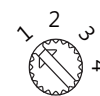

Device No.	Position of switch
0x00	1
0x01	2
0x02	3
0x03	4

6.2.2 CANBus Command list

Command Code	Command Name	Transaction Type	# of data Bytes	Description
0x0000	OPERATION	R/W	1	ON/OFF control ON: 01h OFF: 00h
0x0020	VOUT_SET*	R/W	2	Output voltage set (format: value, F=0.01)
0x0030	IOUT_SET*	R/W	2	Output current set (format: value, F=0.01)
0x0040	FAULT_STATUS	R	2	Abnormal status
0x0050	READ_VIN	R	2	Input voltage read value (format: value, F=0.1)
0x0060	READ_VOUT	R	2	Output voltage read value (format: value, F=0.01)
0x0061	READ_IOUT	R	2	Output current read value (format: value, F=0.01)
0x0062	READ_TEMPERATURE_1	R	2	Internal ambient temperature (format: value, F=0.1)
0x0080	MFR_ID_B0B5	R	6	Manufacture's name
0x0081	MFR_ID_B6B11	R	6	Manufacture's name
0x0082	MFR_MODEL_B0B5	R	6	Manufacture model name
0x0083	MFR_MODEL_B6B11	R	6	Manufacture model name
0x0084	MFR_REVISION_B0B5	R	6	Firmware version
0x0085	MFR_LOCATION_B0B2	R	3	Manufacture place
0x0086	MFR_DATE_B0B5	R	6	Manufacture date
0x0087	MFR_SERIAL_B0B5	R	6	Manufacture serial number
0x0088	MFR_SERIAL_B6B11	R	6	Manufacture serial number
0x00B0	CURVE_CC*	R/W	2	Constant current setting of charge curve (format: value, F=0.01)
0x00B1	CURVE_CV*	R/W	2	Constant voltage setting of charge curve (format: value, F=0.01)
0x00B2	CURVE_FV*	R/W	2	Floating voltage setting of charge curve (format: value, F=0.01)
0x00B3	CURVE_TC*	R/W	2	Taper current setting of charge curve (format: value, F=0.01)
0x00B4	CURVE_CONFIG	R/W	2	Configuration setting of charge curve

Valid when CURVE_CONFIG.CUVE = 1

Command Code	Command Name	Transaction Type	# of data Bytes	Description
0x00B5	CURVE_CC_TIMEOUT	R/W	2	CC charge timeout setting of charging curve
0x00B6	CURVE_CV_TIMEOUT	R/W	2	CV charge timeout setting of charging curve
0x00B7	CURVE_FV_TIMEOUT	R/W	2	FV charge timeout setting of charging curve
0x00B8	CHG_STATUS	R	2	Charging status reporting
0x00C0	SCALING_FACTOR	R	2	Scaling ratio
0x00C1	SYSTEM_STATUS	R	2	System status
0x00C2	SYSTEM_CONFIG	R/W	2	System configuration

Valid when CURVE_CONFIG.CUVE = 1

Note: Setting commands with * at the end support the EEP_OFF and EEP_CONFIG functions. For detailed information on how to enable them, please refer to SYSTEM_CONFIG (0x00C2).

Data Conversion:

The conversion of setting and reading values is defined as following:
Actual value = Communication reading value × Factor (F value). Among them, Factor needs to refer to the definition of SCALING_FACTOR in each model list.

EX: V_{o_real} (actual DC voltage) = READ_VOUT × Factor.

If the Factor of READ_VOUT of a certain model is 0.01, the communication reading value is 0x0960 (hexadecimal) → 2400 (decimal), then $VDC_{real} = 2400 \times 0.01 = 24.00V$.

© Definition of FAULT_STATUS (0x0040):

	Bit7	Bit6	Bit5	Bit4	Bit3	Bit2	Bit1	Bit0
High byte	-	-	-	-	-	-	-	-
Low byte	HI_TEMP	OP_OFF	AC_FAIL	SHORT	OLP	OVP	OTP	-

Low byte

- Bit 1 OTP : Over temperature protection
0 = Internal temperature normal
1 = Internal temperature abnormal
- Bit 2 OVP : DC over voltage protection
0 = DC voltage normal
1 = DC over voltage protected
- Bit 3 OLP : DC over current protection
0 = DC current normal
1 = DC over current protected

Bit 4 SHORT : Short circuit protection

- 0 = Shorted circuit do not exist
- 1 = Shorted circuit protected

Bit 5 AC_FAIL : AC abnormal flag

- 0 = AC input range normal
- 1 = AC input range abnormal

Bit 6 OP_OFF : DC status

- 0 = DC output turned on
- 1 = DC output turned off

Bit 7 HI_TEMP : Internal high temperature alarm

- 0 = Internal temperature normal
- 1 = Internal temperature abnormal

Note: Unsupported settings displays with "0"

©MFR_ID_B0B5 (0x0080) is the first 6 codes of the manufacturer's name (ASCII); MFR_ID_B6B11 (0x0081) is the last 6 codes of the manufacturer's name (ASCII)

EX: manufacturer's name is MEANWELL → MFR_ID_B0B5 is MEANWE ; MFR_ID_B6B11 is LL

MFR_ID_B0B5					
Byte 0	Byte 1	Byte 2	Byte 3	Byte 4	Byte 5
0x4D	0x45	0x41	0x4E	0x57	0x45

MFR_ID_B6B11					
Byte 0	Byte 1	Byte 2	Byte 3	Byte 4	Byte 5
0x4C	0x4C	0x20	0x20	0x20	0x20

©MFR_MODEL_B0B5 (0x0082) is the first 6 codes of the manufacturer's model name(ASCII); MFR_MODEL_B6B11 (0x0083) is the last 6 codes of the manufacturer's model name (ASCII);

EX: Model name is HEP-2300-55 → MFR_MODEL_B0B5 is HEP-23 ; MFR_MODEL_B6B11 is 00-55

MFR_MODEL_B0B5					
Byte 0	Byte 1	Byte 2	Byte 3	Byte 4	Byte 5
0x50	0x48	0x50	0x2D	0x33	0x35

MFR_ID_B6B11					
Byte 6	Byte 7	Byte 8	Byte 9	Byte 10	Byte 11
0x30	0x30	0x2D	0x32	0x34	0x20

©MFR_REVISION_B0B5 (0x0084) is the firmware revision (hexadecimal). A range of 0x00 (R00.0)~0xFE (R25.4) represents the firmware version of an MCU; 0xFF represents no MCU existed.

EX: The supply has two MCUs, the firmware version of the MCU number 1 is version R25.4 (0xFE), the MCU number 2 is version R10.5 (0x69)

Byte 0	Byte 1	Byte 2	Byte 3	Byte 4	Byte 5
0xFE	0x69	0xFF	0xFF	0xFF	0xFF

©MFR_DATE_B0B5 (0x0086) is manufacture date (ASCII)

EX: MFR_DATE_B0B5 is 180101, meaning 2018/01/01

Byte 0	Byte 1	Byte 2	Byte 3	Byte 4	Byte 5
0x31	0x38	0x30	0x31	0x30	0x31

©MFR_SERIAL_B0B5 (0x0087) and MFR_SERIAL_B6B11 (0x0088) are defined as manufacture date and manufacture serial number (ASCII)

EX: The first unit manufactured on 2018/01/01 → MFR_SERIAL_B0B5: 180101 ; MFR_SERIAL_B6B11: 000001

Byte 0	Byte 1	Byte 2	Byte 3	Byte 4	Byte 5
0x31	0x38	0x30	0x31	0x30	0x31

Byte 6	Byte 7	Byte 8	Byte 9	Byte 10	Byte 11
0x30	0x30	0x30	0x30	0x30	0x31

©CURVE_CONFIG(0x00B4, only for charger) :

	Bit7	Bit6	Bit5	Bit4	Bit3	Bit2	Bit1	Bit0
High byte	-	-	-	-	-	FVTOE	CVTOE	CCTOE
Low byte	CUVE	-	-	-	TCS		CUVS	

Low byte

Bit 0:1 CUVS : Charge Curve Selection

00 = Customized charge Curve(default)

01 = Gel Battery

10 = Flooded Battery

11 = AGM Battery

Bit 2:3 TCS : Temperature Compensation Setting

00= disable

01= -3 mV/°C/cell (default)

10= -4 mV/°C/cell

11= -5 mV/°C/cell

Bit 6 STGS : 2/3 Stage Charge Setting

0= 3 stage charge (default)

1= 2 stage charge

Bit 7 CUVE : Charge Curve Function Enable

0= disabled, power supply mode(default)

1= enabled, charger mode

High byte:

Bit 0 CCTOE : Constant Current Stage Timeout Indication Enable

0= disable (default)

1= enabled

Bit 1 CVTOE : Constant Voltage Stage Timeout Indication Enable

0= disable (default)

1= enabled

Bit 2 FTTOE : Float Voltage Stage Timeout Indication Enable

0= disable (default)

1= enabled

Note: Unsupported settings displays with "0"

©CHG_STATUS(0x00B8, only for charger :

	Bit7	Bit6	Bit5	Bit4	Bit3	Bit2	Bit1	Bit0
High byte	FVTOF	CVTOF	CCTOF	-	BTNC	NTCER	-	-
Low byte	-	-	-	-	FVM	CVM	CCM	FULLM

Low byte

Bit 0 FULLM : Fully Charged Mode Status

0= NOT fully charged

1= fully charged

Bit 1 CCM : Constant Current Mode Status

0= the charger NOT in constant current mode

1= the charger in constant current mode

Bit 2 CVM : Constant Voltage Mode Status

0= the charger NOT in constant voltage mode

1= the charger in constant voltage mode

Bit 3 FVM : Float Mode Status

0= the charger NOT in float mode

1= the charger in float mode

High byte:

Bit 2 NTCER : Temperature Compensation Status

0= Temperature Compensation Status

1= the circuitry of temperature compensation has short-circuited

Bit 3 BTNC : Battery Detection

0= battery detected

1= No battery detected

Bit 5 CCTOF : Time Out Flag of Constant Current Mode

0= NO time out in constant current mode

1= constant current mode timed out

Bit 6 CVTOF : Time Out Flag of Constant Voltage Mode

0= NO time out in constant voltage mode

1= constant voltage mode timed out

Bit 7 FTTOF : Time Out Flag of Float Mode

0= NO time out in float mode

1= float mode timed out

Note: Unsupported settings displays with "0"

Charge curve illustration:

3 Stage Charge

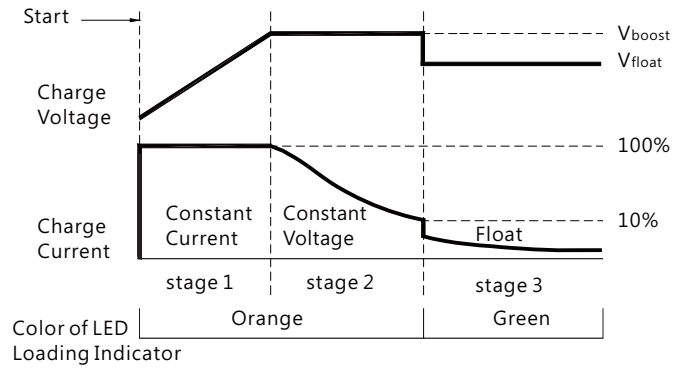

2 Stage Charge

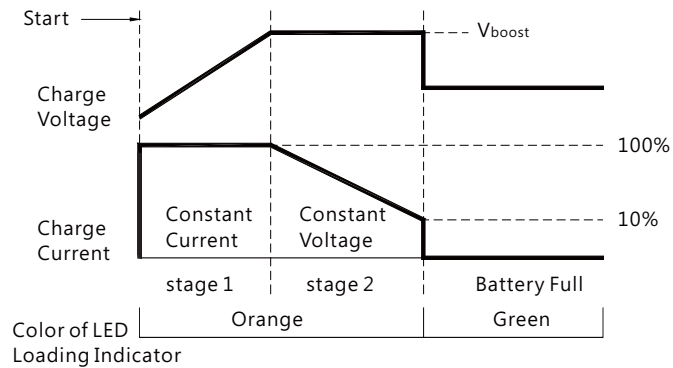

©SCALING_FACTOR (0x00C0) :

Bit7~Bit0								
byte4~5	Reserved							
	Bit7	Bit6	Bit5	Bit4	Bit3	Bit2	Bit1	Bit0
byte3	Reserved				IIN Factor			
	Bit7	Bit6	Bit5	Bit4	Bit3	Bit2	Bit1	Bit0
byte2	CURVE_TIMEOUT Factor				TEMPERATURE_1 Factor			
	Bit7	Bit6	Bit5	Bit4	Bit3	Bit2	Bit1	Bit0
byte1	FAN_SPEED Factor				VIN Factor			
	Bit7	Bit6	Bit5	Bit4	Bit3	Bit2	Bit1	Bit0
byte0	IOUT Factor				VOUT Factor			

byte0:

Bit 0:3 3 VOUT Factor : The factor of output voltage
0x0=Output voltage relevant commands not supported

- 0x4=0.001
- 0x5=0.01
- 0x6=0.1
- 0x7=1.0
- 0x8=10
- 0x9=100

Bit 4:7 IOUT Factor : The Factor of DC current

0x0=Output current relevant commands not supported

- 0x4=0.001
- 0x5=0.01
- 0x6=0.1
- 0x7=1.0
- 0x8=10
- 0x9=100

byte1:

Bit 0:3 VIN Factor : The Factor of AC input voltage

0x0=AC input relevant commands not supported

- 0x4=0.001
- 0x5=0.01
- 0x6=0.1
- 0x7=1.0
- 0x8=10
- 0x9=100

Bit 4:7 FAN_SPEED Factor : The Factor of fan speed

0x0=Fan speed relevant commands not supported

- 0x4=0.001
- 0x5=0.01
- 0x6=0.1
- 0x7=1.0
- 0x8=10
- 0x9=100

byte2:

Bit 0:3 TEMPERATURE_1 Factor : The Factor of internal ambient temperature

0x0=internal ambient temperature relevant commands not supported

0x4=0.001

0x5=0.01

0x6=0.1

0x7=1.0

0x8=10

0x9=100

Bit 4:7 CURVE_TIMEOUT Factor : The Factor of CC/CV/Float timeout

0x0=CURVE_TIMEOUT relevant commands not supported

0x4=0.001

0x5=0.01

0x6=0.1

0x7=1.0

0x8=10

0x9=100

byte3:

Bit 0:3 IIN Factor : The Factor of AC input current

0x0=AC input current relevant commands not supported

0x4=0.001

0x5=0.01

0x6=0.1

0x7=1.0

0x8=10

0x9=100

©SYSTEM_STATUS (0x00C1) :

	Bit7	Bit6	Bit5	Bit4	Bit3	Bit2	Bit1	Bit0
High byte	-	-	-	-	-	-	-	-
Low byte	-	EEPER	INITIAL- LSTATE	ADL_ON	-	-	DC_OK	-

Low byte:

Bit 1 DC_OK : Secondary DD output voltage status

0 = Secondary DD output voltage status TOO LOW

1 = Secondary DD output voltage status NORMAL

Bit 4 ADL_ON : Active dummy load control status

0 = Active dummy load off/function not supported

1 = Active dummy load on

Bit 5 INITIAL_STATE : Device initialized status

0 = In initialization status

1 = NOT in initialization status

Bit 6 EEPEER : EEPROM data access error

0 = EEPROM data access normal

1 = EEPROM data access error

Note: Unsupported settings displays with "0"

©SYSTEM_CONFIG (0x00C2) :

	Bit7	Bit6	Bit5	Bit4	Bit3	Bit2	Bit1	Bit0
High byte	-	-	-	-	-	EEP_OFF	EEP_CONFIG	
Low byte	-	-	-	-	-	OPERATION_INIT		CAN_CTRL

Low byte:

Bit 0 CAN_CTRL : CANBus communication control status

0 = The output voltage/current defined by control over SVR/PV/PC

1 = The output voltage, current, ON/OFF control defined by control over CANBus (VOUT_SET, IOUT_SET, OPERATION)

Bit 1:2 OPERATION_INIT : Pre-set value of power on operation command

0b00 = Power OFF, pre-set 0x00(OFF)

0b01 = Power ON, pre-set 0x01(ON)

0b10 = Pre-set is previous set value

0b11 = not used, reserved

High Byte:

Bit 0:1 EEP_CONFIG: EEPROM Configuration

00: Immediate. Changes to parameters are written to EEPROM immediately (factory default)

01: 1 minute delay. Write changes to EEPROM if all parameters remain unchanged for 1 minute

10: 10 minute delay. Write changes to EEPROM if all parameters remain unchanged for 10 minutes

11: Reserved

Bit 2 EEP_OFF: EEPROM storage function ON/OFF

0: Enable. Parameters to be saved into EEPROM (factory default)

1: Disable. Parameters NOT to be saved into EEPROM

6.2.3 Communication Examples

The following provides examples of command sending and data reading for the CANBus protocol.

6.2.3.1 Sending command

The master adjusts output voltage of the unit with address "01" to 30V.

CAN ID	DLC (data length)	Command code	Parameters
0X000C0101	0x4	0x2000	0xB80B

Command code: 0x0020 (VOUT_SET) → 0x20(Lo) + 0x00(Hi)

Parameters: 30V → 3000 → 0x0BB8 → 0xB8(Lo) + 0x0B(Hi)

NOTE: Conversion factor for VOUT_SET is 0.01, so $\frac{30V}{F=0.01} = 3000$

6.2.3.2 Reading data or status

The master reads operation setting from the unit with address "00".

CAN ID	DLC (data length)	Command code
0X000C0100	0x2	0x0000

The unit with address "00" returns data below:

CAN ID	DLC (data length)	Command code	Parameters
0X000C0000	0x3	0x0000	0x01

Parameters: 0x01 ON, meaning that the unit with address "00" is operating.

6.3 Modbus Communication Interface

The device supports Modbus RTU with the master-slave principle.

Users are able to read and write parameters of the device through the protocol, including remote ON/OFF, output voltage/current setting, etc. During data transfer, please follow the principle of first sending the Hi byte and then the Lo byte except Error Check (CRC16 checksum).

Physical Layer setting as below:

Control	Setting
Baud Rate	115200
Data Bits	8
Stop Bit	1
Parity	None
Flow Control	None

6.3.1 Communication Timing

Min. request period (Controller to PSU/CHG): 50mSec ◦

Max. response time (PSU/CHG to Controller): 12.5mSec ◦

Min. packet margin time (Controller to PSU/CHG): 12.5mSec ◦

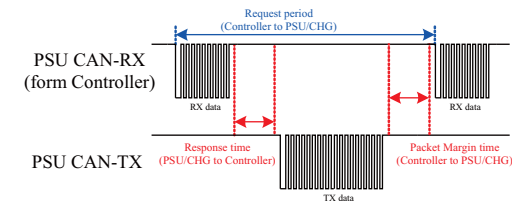

6.3.2 Modbus Frame Encapsulation

Modbus RTU consists of Additional Address, Function Code, Data and Error Check.

Additional Address	Function Code	Data	Error Check
1 byte	1 byte	N bytes	2 bytes

Additional address (1byte) : defines PSU/Charger slave ID.

Function code (1byte) : The function code is used to tell the slave what kind of action to perform.

Data (N bytes):For data exchange, contents and data length are dependent on different function codes.

Error Check (2bytes) : utilizes CRC-16.

6.3.3 Additional Address Definition

Additional address is the slave ID of the device. Each HEP-2300 unit should have their unique and own device address to communicate over the bus.

Slave ID	Description
0x8X	X mean device address (defined by Address rotary switch)
0x00	Broadcast

Note: 1.X means the address of HEP-2300 (which can be assigned by the address rotary switch, range from 0 ~ 3)

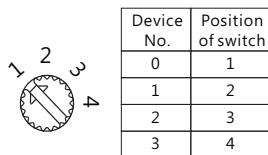

2.Broadcast is only for command write and not for read.

6.3.4 Function Code Description

The main purpose of the function codes is to tell the slave what kind of action to perform. For example: Function code 03 will query the slave to read holding registers and respond with the master their contents.

Code	Function Code
0x03	Read Holding Register
0x04	Read Input Register
0x06	Preset Single Register

6.3.5 Data Field and Command Lists

Data field provides additional information by the slave to complete the action specified by the function code(FC) in a request. The data field typically includes register addresses, count values, and written data. There are several forms according to the function codes.

FC = 03/04

Starting Address	Quantity of (Input) Registers
2 Bytes	2 Bytes

FC = 06

Register Address	Register Value
2 Bytes	2 Bytes

The following is data description of register addresses.

Register address	Command Name	Function code	# of data Bytes	Description
0x0000	OPERATION	0x03 · 0x06	1	Remote ON/OFF control ON: 0x0001 OFF: 0x0000
0x0020	VOUT_SET*	0x03 · 0x06	2	Output voltage set (format: value, F=0.01)
0x0030	IOUT_SET*	0x03 · 0x06	2	Output current set (format: value, F=0.01)
0x0040	FAULT_STATUS	0x03	2	Abnormal status
0x0050	READ_VIN	0x04	2	Input voltage read value (format: value, F=0.1)
0x0060	READ_VOUT	0x04	2	Output voltage read value (format: value, F=0.01)
0x0061	READ_IOUT	0x04	2	Output current read value (format: value, F=0.01)
0x0062	READ TEMPERATURE_1	0x04	2	Internal ambient temperature (format: value, F=0.1)
0x0080~0x0082	MFR_ID_B0B5	0x03	6	Manufacture's name
0x0083~0x0085	MFR_ID_B6B11	0x03	6	Manufacture's name
0x0086~0x0088	MFR_MODEL_B0B5	0x03	6	Manufacture model name

Register address	Command Name	Function code	# of data Bytes	Description
0x0089~0x008B	MFR_MODEL_B6B11	0x03	6	Manufacture model name
0x008C~0x008E	MFR_REVISION_B0B5	0x03	6	Firmware version
0x008F~0x0090	MFR_LOCATION_B0B2	0x03	3	Manufacture place
0x0091~0x0093	MFR_DATE_B0B5	0x03	3	Manufacture date
0x0094~0x0096	MFR_SERIAL_B0B5	0x03	3	Manufacture serial number
0x0097~0x0099	MFR_SERIAL_B6B11	0x03	1	Manufacture serial number
0x00B0	CURVE_CC*	0x03 · 0x06	2	Constant current setting of charge curve (format: value, F=0.01)
0x00B1	CURVE_CV*	0x03 · 0x06	2	Constant voltage setting of charge Curve (format: value, F=0.01)
0x00B2	CURVE_FV*	0x03 · 0x06	2	Floating voltage setting of charge curve (format: value, F=0.01)
0x00B3	CURVE_TC*	0x03 · 0x06	2	Taper current setting of charge curve (format: value, F=0.01)
0x00B4	CURVE_CONFIG	0x03 · 0x06	2	Configuration setting of charge curve
0x00B5	CURVE_CC_TIMEOUT	0x03 · 0x06	2	CC charge timeout setting of charging curve
0x00B6	CURVE_CV_TIMEOUT	0x03 · 0x06	2	CV charge timeout setting of charging curve
0x00B7	CURVE_FV_TIMEOUT	0x03 · 0x06	2	FV charge timeout setting of charging curve
0x00B8	CHG_STATUS	0x03	2	Charging status reporting
0x00C0	SCALING_FACTOR	0x03	2	Scaling ratio
0x00C3	SYSTEM_STATUS	0x03	2	System status
0x00C4	SYSTEM_CONFIG	0x03 · 0x06	2	System configuration

Note: Setting commands with * at the end support the EEP_OFF and EEP_CONFIG functions. For detailed information on how to enable them, please refer to SYSTEM_CONFIG (0x00C4).

Data conversion:

The conversion of setting and reading values is defined as following:
Actual value = Communication reading value Factor (F value). Among them, Factor needs to refer to the definition of SCALING_FACTOR in each model list.

EX: VDC_real (actual DC voltage) = READ_VOUT x Factor. If the Factor of READ_VOUT of a certain model is 0.01, the communication reading value is 0x0960 (hexadecimal) → 2400 (decimal), then VDC_real = 2400 x 0.01 = 24.00V.

©FAULT_STATUS (0x0040) :

	Bit7	Bit6	Bit5	Bit4	Bit3	Bit2	Bit1	Bit0
High byte	-	-	-	-	-	-	-	-
Low byte	HI_TEMP	OP_OFF	AC_FAIL	SHORT	OLP	OVP	OTP	-

Low byte:

Bit 1 OTP : Over temperature protection

0 = Internal temperature normal

1 = Internal temperature abnormal

Bit 2 OVP : Output over-voltage protection

0 = Output voltage normal

1 = Output over voltage protected

Bit 3 OLP : Output over current protection

0 = Output current normal

1 = Output over-current protected

Bit 4 SHORT : Short circuit protection

0 = Shorted circuit do not exist

1 = Shorted circuit protected

Bit 5 AC_FAIL : AC abnormal flag

0 = AC range normal

1 = AC range abnormal

Bit 6 OP_OFF : DC status

0 = DC turned on

1 = DC turned off

Bit 7 HI_TEMP : Internal high temperature alarm

0 = Internal temperature normal

1 = Internal temperature abnormal

Note: Unsupported settings displays with "0"

©MFR_ID_B0B5 (0x0080 -0x0082) is the first 6 codes of the manufacturer's name (ASCII); MFR_ID_B6B11(0x0083 -0x0085) is the last 6 codes of the manufacturer's name (ASCII)

EX: manufacturer's name is MEANWELL → MFR_ID_B0B5 is MEANWE ; MFR_ID_B6B11 is LL

MFR_ID_B0B5					
Byte 0	Byte 1	Byte 2	Byte 3	Byte 4	Byte 5
0x4D	0x45	0x41	0x4E	0x57	0x45

MFR_ID_B6B11					
Byte 0	Byte 1	Byte 2	Byte 3	Byte 4	Byte 5
0x4C	0x4C	0x20	0x20	0x20	0x20

©MFR_MODEL_B0B5 (0x0086 -0x0088) is the first 6 codes of the manufacturer's model name ' (ASCII); MFR_MODEL_B6B11(0x0089 -0x008B) is the last 6 codes of the manufacturer's model ' name (ASCII)

EX: Model name is HEP-2300-115 → MFR_MODEL_B0B5 is HEP-2300 ; MFR_MODEL_B6B11 is 00-115

MFR_MODEL_B0B5					
Byte 0	Byte 1	Byte 2	Byte 3	Byte 4	Byte 5
0x50	0x48	0x50	0x2D	0x33	0x35

MFR_MODEL_B6B11					
Byte 6	Byte 7	Byte 8	Byte 9	Byte 10	Byte 11
0x30	0x30	0x2D	0x32	0x34	0x20

©MFR_REVISION_B0B5 (0x008C -0x008E) is the firmware revision. A range of 0x00 hexadecimal (R00.0)~0xFE (R25.4) represents the firmware version of an MCU; 0xFF represents no MCU existed

EX: The supply has two MCUs, the firmware version of the MCU number 1 is version R25.4 (0xFE), the MCU number 2 is version R10.5 (0x69)

Byte 0	Byte 1	Byte 2	Byte 3	Byte 4	Byte 5
0xFE	0x69	0xFF	0xFF	0xFF	0xFF

©MFR_DATE_B0B5 (0x0091 -0x0093) is manufacture date (ASCII)

EX: MFR_DATE_B0B5 is 180101, meaning 2018/01/01

Byte 0	Byte 1	Byte 2	Byte 3	Byte 4	Byte 5
0x31	0x38	0x30	0x31	0x30	0x31

©MFR_SERIAL_B0B5 (0x0094 -0x0096) and MFR_SERIAL_B6B11 (0x0097 -0x0099) are defined as manufacture date and manufacture serial number (ASCII)

EX: The first unit manufactured on 2018/01/01 → MFR_SERIAL_B0B5: 180101 ; MFR_SERIAL_B6B11: 000001

Byte 0	Byte 1	Byte 2	Byte 3	Byte 4	Byte 5
0x31	0x38	0x30	0x31	0x30	0x31

Byte 6	Byte 7	Byte 8	Byte 9	Byte 10	Byte 11
0x30	0x30	0x30	0x30	0x30	0x31

©CURVE_CONFIG(0x00B4, only for charger) :

	Bit7	Bit6	Bit5	Bit4	Bit3	Bit2	Bit1	Bit0
High byte	-	-	-	-	-	FVTOE	CVTOE	CCTOE
Low byte	CUVE	STGS	-	-	TCS		CUVS	

Low byte

Bit 0:1 CUVS : Charge Curve Selection

00 = Customized charge Curve(default)

01 = Gel Battery

10 = Flooded Battery

11 = AGM Battery

Bit 2:3 TCS : Temperature Compensation Setting

00 = disable

01 = -3 mV/°C/cell (default)

10 = -4 mV/°C/cell

11 = -5 mV/°C/cell

Bit 6 STGS : 2/3 Stage Charge Setting
 0= 3 stage charge(default, CURVE_CV and CURVE_FV)
 1= 2 stage charge (only CURVE_CV)

Bit 7 CUVE : Charge Curve Function Enable
 0= disabled, power supply mode(default)
 1= enabled, charger mode

High byte:
 Bit 0 CCTOE : Constant Current Stage Timeout Indication Enable
 0= disable (default)
 1= enabled

Bit 1 CVTOE : Constant Voltage Stage Timeout Indication Enable
 0= disable (default)
 1= enabled

Bit 2 FTTOE : Float Voltage Stage Timeout Indication Enable
 0= disable (default)
 1= enabled

Note: Unsupported settings displays with "0"

©CHG_STATUS(0x00B8, only for charger) :

	Bit7	Bit6	Bit5	Bit4	Bit3	Bit2	Bit1	Bit0
High byte	FVTOF	CVTOF	CCTOF	-	BTNC	NTCER	-	-
Low byte	-	-	-	-	FVM	CVM	CCM	FULLM

Low byte
 Bit 0 FULLM : Fully Charged Mode Status
 0= NOT fully charged
 1= fully charged

Bit 1 CCM : Constant Current Mode Status
 0= the charger NOT in constant current mode
 1= the charger in constant current mode

Bit 2 CVM : Constant Voltage Mode Status
 0= the charger NOT in constant voltage mode
 1= the charger in constant voltage mode

Bit 3 FVM : Float Mode Status
 0= the charger NOT in float mode
 1= the charger in float mode

High byte:
 Bit 2 NTCER : Temperature Compensation Status
 0= NO short-circuit in the circuitry of temperature compensation
 1= the circuitry of temperature compensation has short-circuited

Bit 3 BTNC : Battery Detection
 0= battery detected
 1= No battery detected

Bit 5 CCTOF : Time Out Flag of Constant Current Mode
 0= NO time out in constant current mode
 1= constant current mode timed out

Bit 6 CVTOF : Time Out Flag of Constant Voltage Mode
 0= NO time out in constant voltage mode
 1= constant voltage mode timed out

Bit 7 FTTOF : Time Out Flag of Float Mode
 0= NO time out in float mode
 1= float mode timed out

Note: Unsupported settings displays with "0"

Charge curve illustration:

2 Stage Charge

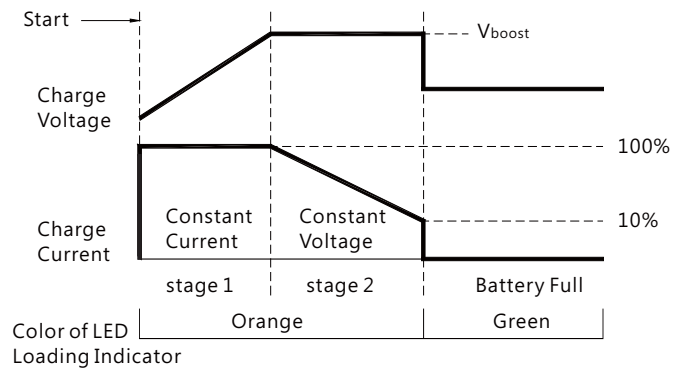

Color of LED Loading Indicator

3 Stage Charge

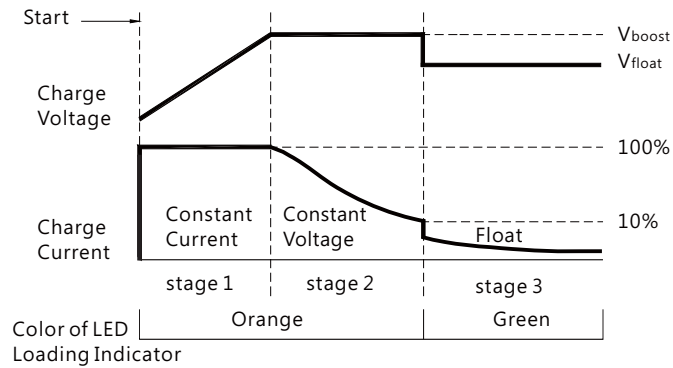

Color of LED Loading Indicator

©SCALING_FACTOR (0x00C0) :

Bit7~Bit0								
byte4~5	Reserved							
	Bit7	Bit6	Bit5	Bit4	Bit3	Bit2	Bit1	Bit0
byte3	Reserved				IIN Factor			
	Bit7	Bit6	Bit5	Bit4	Bit3	Bit2	Bit1	Bit0
byte2	CURVE_TIMEOUT Factor				TEMPERATURE_1 Factor			
	Bit7	Bit6	Bit5	Bit4	Bit3	Bit2	Bit1	Bit0
byte1	FAN_SPEED Factor				VIN Factor			
	Bit7	Bit6	Bit5	Bit4	Bit3	Bit2	Bit1	Bit0
byte0	IOUT Factor				VOUT Factor			

byte0:

Bit 0:3 VOUT Factor : The factor of output voltage

0x0=Output voltage relevant commands not supported

0x4=0.001

0x5=0.01

0x6=0.1

0x7=1.0

0x8=10

0x9=100

0xA~0xF= Reserved

Bit 4:7 IOUT Factor : The Factor of DC current

0x0=Output current relevant commands not supported

0x4=0.001

0x5=0.01

0x6=0.1

0x7=1.0

0x8=10

0x9=100

0xA~0xF= Reserved

byte1:

Bit 0:3 VIN Factor : The Factor of AC input voltage

0x0=AC input relevant commands not supported

0x4=0.001

0x5=0.01

0x6=0.1

0x7=1.0

0x8=10

0x9=100

0xA~0xF= Reserved

Bit 4:7 FAN_SPEED Factor : The Factor of fan speed

0x0=Fan speed relevant commands not supported

0x4=0.001

0x5=0.01

0x6=0.1

0x7=1.0

0x8=10

0x9=100

0xA~0xF= Reserved

byte2:

Bit 0:3 TEMPERATURE_1 Factor : The Factor of internal ambient temperature

0x0=internal ambient temperature relevant commands not supported

0x4=0.001

0x5=0.01

0x6=0.1

0x7=1.0

0x8=10

0x9=100

0xA~0xF= Reserved

Bit 4:7 CURVE_TIMEOUT Factor : The Factor of CC/CV/Float timeout

0x0=CURVE_TIMEOUT relevant commands not supported

0x4=0.001

0x5=0.01

0x6=0.1

0x7=1.0

0x8=10

0x9=100

0xA~0xF= Reserved

byte3:

Bit 0:3 IIN Factor : The Factor of AC input current

0x0=AC input current relevant commands not supported

0x4=0.001

0x5=0.01

0x6=0.1

0x7=1.0

0x8=10

0x9=100

0xA~0xF= Reserved

©SYSTEM_STATUS (0x00C3) :

	Bit7	Bit6	Bit5	Bit4	Bit3	Bit2	Bit1	Bit0
High byte	-	-	-	-	-	-	-	-
Low byte	-	EEPER	INITIA-LSTATE	ADL_ON	-	-	DC_OK	-

Low byte:

Bit 1 DC_OK : Secondary DD output voltage status

0 = Secondary DD output voltage status TOO LOW

1 = Secondary DD output voltage status NORMAL

Bit 4 ADL_ON : Active dummy load control status

0 = Active dummy load off/function not supported

1 = Active dummy load on

Bit 5 INITIAL_STATE : Device initialized status

0 = In initialization status

1 = NOT in initialization status

Bit 6 EEPER : EEPROM data access error

0 = EEPROM data access normal

1 = EEPROM data access error

Note: Unsupported settings displays with "0"

©SYSTEM_CONFIG (0x00C4) :

	Bit7	Bit6	Bit5	Bit4	Bit3	Bit2	Bit1	Bit0
High byte	-	-	-	-	-	EEP_OFF	EEP_CONFIG	
Low byte	-	-	-	-	-	OPERATION_INI	MOD_CTRL	

Low byte:

Bit 0

MOD_CTRL : Modbus communication control status

0 = The output voltage/current defined by control over SVR/PV/PC

1 = The output voltage, current, ON/OFF control defined by control over Modus (VOUT_SET, IOUT_SET, OPERATION)

Bit 1:2

OPERATION_INIT : Pre-set value of power on operation command

0b00 = Power OFF, pre-set 0x00(OFF)

0b01 = Power ON, pre-set 0x01(ON)

0b10 = Pre-set is previous set value

0b11 = not used, reserved

High Byte:

Bit 0:1 EEP_CONFIG: EEPROM Configuration

00: Immediate. Changes to parameters are written to EEPROM immediately (factory default)

01: 1 minute delay. Write changes to EEPROM if all parameters remain unchanged for 1 minute

10: 10 minute delay. Write changes to EEPROM if all parameters remain unchanged for 10 minutes

11: Reserved

Bit 2 EEP_OFF: EEPROM storage function ON/OFF

0: Enable. Parameters to be saved into EEPROM (factory default)

1: Disable. Parameters NOT to be saved into EEPROM

6.3.7 Communication Examples

The following provides examples of request and response for each function code of the Modbus RTU.

6.3.7.1 Read Holding Registers (FC=03)

The request message specifies the starting register and quantity of registers to be read.

For example: the master requests the content of analog output holding registers 0x008C-0x008E (MFR_REVISION_B0B5) from slave 0.

Request:

0x80	0x03	0x008C	0x0003	0xDA31
------	------	--------	--------	--------

0x80: Slave ID 0

0x03: Function code 3 (Read Analog Output Holding R Registers)

0x008C: The Data Address of the first register requested.

0x0003: The total number of registers requested (Read 3 registers from 0x008C to 0x008E)

0xDA31: CRC16 Error Check. Please be aware that CRC sending the Lo byte first.

Response:

0x80	0x03	0x06	0x0AFFFFFFFFFF	0x7DEC
------	------	------	----------------	--------

0x80: Slave ID 0

0x03: Function code 3 (Read Analog Output Holding R Registers)

0x06: The number of data bytes to follow (6 bytes)

0x0A FF FF FF FF FF: means that the firmware version of the MCU number1 is R01.0.

0x7DEC: CRC16 Error Check. Please be aware that CRC sending the Lo byte first.

6.3.7.2 Read Input Register (FC=04)

The request message specifies the starting register and quantity of registers to be read. For example: The master requests the content of analog input register 0x0060 (READ_VOUT) from salve 0

Request:

0x80	0x04	0x0060	0x0001	0x2FC5
------	------	--------	--------	--------

0x80: Slave ID 0

0x04: Function code 4 (Read Analog Input Registers)

0x0060: The Data Address of the first register requested

0x0001: he total number of registers requested (read only 1 registers from 0x0060)

0x2FC5: CRC16 Error Check. Please be aware that CRC sending the Lo byte first.

Response:

0x80	0x04	02	0x157C	0x0D03
------	------	----	--------	--------

0x80: Slave ID 0

0x04: Function code 4 (Read Analog Input Register)

0x02: The number of data bytes to follow (2 bytes)

0x157C: The contents of register: 0x0060(READ_VOUT). $157C_{16} = 5500_{10} = 55.00V$

0x0D03: CRC16 Error Check. Please be aware that CRC sending the Lo byte

6.3.7.3 Write Single Register (FC=06)

The request message specifies the register reference to be written.

For example: the master writes PSU ON to analog output holding register of 0x0000 (OPERATION) for salve 0

Request:

0x80	0x06	0x0000	0x0001	0x561B
------	------	--------	--------	--------

0x80: Slave ID 0

0x06: Function code 6 (Preset Single Register)

0x0000: The Data Address of the register

0x0001: The value to write

0x561B: CRC16 Error Check. Please be aware that CRC sending the Lo byte first.

Response:

The normal response is an echo of the query, returned after the register contents have been written.

6.4 Value range and tolerance

(1)Display parameters

Command Name	Model	Display value range	Tolerance
READ_VIN	ALL	80~305V	±10V
READ_VOUT	55V	0~57.6V	±0.55V
	115V	0~138V	±1.15V
	230V	0~260V	±2.3V
	380V	0~400V	±3.8V
READ_IOUT (Note. ii)	55V	0~57.6A	±0.53A
	115V	0~24A	±0.22A
	230V	0~12.72A	±0.12A
	380V	0~8.28A	±0.08A
READ_TEMPERATURE_1	ALL	-40~110°C	±5°C

(2)Control parameters

Command Name	Model	Adjustable range	Tolerance	Default
OPERATION	ALL	PM: 00h(OFF)/80h(ON) CAN/MOD: 00h(OFF)/01h(ON)	N/A	ON
VOUT_COMMAND	55V	55V	N/A	55V
VOUT_TRIM (PMbus only)	55V	-31~2.6V	±0.55V	0V
	115V	-57.5~23V	±1.15V	0V
	230V	-122~30V	±2.3V	0V
	380V	-213~20V	±3.8V	0V
VOUT_SET (CAN bus and Modbus only)	55V	24 ~ 57.6V	±0.55V	0V
	115V	57.5 ~ 138V	±1.15V	0V
	230V	108 ~ 260V	±2.3V	0V
	380V	167 ~ 400V	±3.8V	0V

Command Name	Model	Adjustable range	Tolerance	Default
IOUT_SET	55V	9.6~52.8A	±0.53A	52.8A
	115V	4~22A	±0.22A	22A
	230V	2.12~11.66A	±0.12A	11.66A
	380V	1.38~7.59A	±0.08A	7.59A
CURVE_ICHG	55V	8~40A	±0.4A	40A
CURVE_VBST	55V	36~57.6V	±0.55V	57.6V
CURVE_VFLOAT	55V	36~VBST	±0.55V	55.2V
CURVE_ITAPER	55V	2~12A	±0.4A	4A
CURVE_CONFIG	55V	N/A	N/A	0004h
CURVE_CC_TIMEOUT	55V	60~64800 minute	±5 minute	600 minute
CURVE_CV_TIMEOUT				
CURVE_FLOAT_TIMEOUT				
SYSTEM_CONFIG	ALL	N/A	N/A	02h

Note:

i. READ_IOUT will display ZERO amp when output current is less than values in the table below.

Model	Minimum readable
55V	1.94A±0.53A
115V	0.8A±0.22A
230V	0.42A±0.12A
380V	0.28A±0.08A

ii. Owing to the limited write cycles of the EEPROM, it is advisable to consider using the SYSTEM_CONFIG (PM: BEh; CAN: 0x00C2; MOD: 0x00C4) command to select an appropriate EEPROM writing logic, especially if communication settings are frequently altered.

iii. Changing parameters to CUVE (Low byte: Bit 7) of CURVE_CONFIG command requires a reboot to take effect.

iv. In charger mode, Remote OFF/ON or OPERATION OFF/ON, as well as AC recycling, can be used to activate new curve procedures and import parameters and settings for a new curve profile. Additionally, they can also release protections caused by CURVE_CC_TIMEOUT, CURVE_CV_TIMEOUT, or CURVE_TP_TIMEOUT due to timeouts.

v. In charger mode, when EEP_OFF of SYSTEM_CONFIG (PM: Beh; CAN: 0x00C2; MOD: 0x00C4) is set to logic 1 (parameters NOT to be saved into EEPROM), changes to charge curve parameters, such as CURVE_CC, CURVE_CV, CURVE_FV, and CURVE_TV, can still take effect after remote OFF/ON or OPERATION OFF/ON. However, the new setting values for a new curve profile will be lost if EEP_OFF of SYSTEM_CONFIG is at logic 1 and AC is recycled.

7. Protections and Trouble Shooting

7.1 Protections

7.1.1 Over Temperature Protection (OTP) and Alarm (T-Alarm only for terminal type)

Built-in thermal detection circuit, once the internal temperature exceeds a threshold value, the supply will shut down automatically. Please switch off the supply, remove all possible causes and then leave the supply cooling down to a normal working temperature (approximate 10 minutes – 1 hour) before re-power on again.

OPT(PIN11) to OTP-GND(PIN9)	Condition
Open	Normal Temp.
Short	Abnormal temp.

7.1.2 AC Fail(only for terminal type)

When AC voltage is too low, HEP-2300 will enter protection mode to prevent damaging itself. The supply will restore automatically when AC voltage is back to a normal range.

AC Fail(PIN8) to AC Fail-GND(PIN6)	Condition
Short	AC voltage normal
Open	AC voltage too low

7.1.3 Short Circuit Protection

When there is short circuit at output of HEP-2300, the supply will enter protection mode and shut down. Repower on to restore after short-circuit condition is resolved.

7.1.4 Over Load Protection

When the load current exceeds $110\% \pm 5\%$ of the rated current, protection mode will be triggered. Repower on to restore after over-current condition is resolved.

7.1.5 Over Voltage Protection

When the output voltage is too high, the over-voltage protection circuit will be triggered. Repower on to restore after over-voltage condition is resolved.

7.2 Trouble Shooting

Failure Stage	Possible Cause	Suggested Solution
The supply is not working	Remote OFF	Make sure remote ON-OFF is connected to +12V-AUX
Battery cannot be fully charged	Battery aged or malfunction	Replace a new battery
	Small cross-section of cable	Choose a proper cable for usage
	Wrong charging curve	Double check the characteristic of battery
LED indicator showed abnormal situation	Over temperature	Re-power on the charger after ambient temperature dropped down to a normal level
	Battery's BMS causing malfunction of charger	Please contact battery's manufacturer for details
	Battery voltage incompatible	Please check the specification of battery for compatibility
	Abnormal battery detected	Please ensure the status of battery is normal

If you are unable to clarify the problem you are facing, please contact MEAN WELL or any of our distributors for repair service.

8.Warranty

This product provides six years warranty under normal usage. Do not replace parts or any form of modification to the product in order to keep the warranty effectively.

※ MEAN WELL possesses the right to adjust the content of this manual.

Please refer to the latest version of manual on our website.

<https://www.meanwell.com>



明緯企業股份有限公司

MEAN WELL ENTERPRISES CO., LTD.

248 新北市五股區五權三路28號

No.28, Wuquan 3rd Rd., Wugu Dist., New Taipei City 248, Taiwan

Tel:886-2-2299-6100 Fax:886-2-2299-6200

<http://www.meanwell.com> E-mail:info@meanwell.com