

UHP-2500

Communication Note

1.Communication Protocol	1
1.1 PMBus Addressing and CAN ID setting	1
1.2 PMBus Command List	2
1.2.1 PMBus Data Range and Tolerance	4
1.2.2 Notes on PMBus	5
1.2.3 Communication Example - Practical Operation of Power Supplu Mode	6
1.3 CANBus Communication Interface	7
1.3.1 CANBus Command list	8
1.3.2 Definition and contents of CANBus Command list	9
1.3.3 CANBus Value Range and Tolerance	13
1.3.4 CANBus Communication example	13
2.Factory Resetting	15



UHP-2500 Communication Note

1. Communication Protocol

There are two means to control the power supply, analog signals and digital communication. Analog is the default setting for the supply, signals including PV, PC and SVR can be used immediately once receiving the supply. The digital communication of PMBus or CAN bus is initially uncontrollable but readable. To activate the digital communication, please set PM_CTRL/CAN_CTRL of SYSTEM_CONFIG(PM: BEh; CAN: 0x00C2) at "1" and then reboot the supply. Once the digital communication dominates the supply, the analog signals become invalid.

NOTE: 1. At default setting of analog, the following commands are invalid but can be written while other commands are effective: OPERATION(PM:01h; CAN: 0x0000), VOUT_TRIM/VOUT_SET(PM: 22h; CAN: 0x0020) and IOU_OC_FAULT_LIMIT/OUT_SET(PM: 46h; CAN: 0x0030).

2. All written parameters of commands: PM: 01h, 22h and 46h; CAN: 0x0000, 0x0020 and 0x0030 are saved into EEPROM and take effect after the digital is activated.

1.1 PMBus Addressing and CAN ID setting

⊙ Each UHP-2500 unit should have their unique and own device address to communicate over the bus.

*PMBus 7-bit addressing definition:

MSB				LSB		
1	0	0	0	A2	A1	A0

*CAN message ID definition :

Message ID	Description
0x000C00XX	UHP-2500 to Controller Message ID
0x000C01XX	Controller to UHP-2500 Message ID
0x000C01FF	Controller broadcasts to UHP-2500

XX means the CAN ID of UHP-2500

A0- A2 allow users to designate an address for UHP-2500 units; these three bits are defined through a 3-pole DIP switch on the terminal end of the unit. There are up to 8 different addresses available to be assigned. When DIP switch in the "ON" position means logic "0"; when it is in the "OFF" position, meaning logic "1", for example, position 3 in "OFF", the corresponding bit, A2, is set to logic "1". Please refer to Table 4-1 for the detailed setup advice.



Module No.	Device address/ID		
	A0	A1	A2
	DIP switch position		
	1	2	3
0	ON	ON	ON
1	OFF	ON	ON
2	ON	OFF	ON
3	OFF	OFF	ON

Module No.	Device address/ID		
	A0	A1	A2
	DIP switch position		
	1	2	3
4	ON	ON	OFF
5	OFF	ON	OFF
6	ON	OFF	OFF
7	OFF	OFF	OFF

Table 1-1

1.2 PMBus Command List

©The command list of the UHP-2500 is shown in Table 1-2. It is compliant with the standard protocol of PMBus Rev 1.1. For more detailed information, please refer to PMBus official website (<http://pmbus.org/specs.html>)

Command Code	Command Name	Transaction Type	# of data Bytes	Description
01h	OPERATION	R/W Byte	1	Remote ON/OFF control
02h	ON_OFF_CONFIG	Read Byte	1	ON/OFF function configuration
19h	CAPABILITY	Read Byte	1	Capabilities of a PMBus device
20h	VOUT_MODE	R Byte	1	Define data format for output voltage (format: Linear 16, N= -9)
21h	VOUT_COMMAND	R Word	2	Output voltage setting value (format: Linear 16, N= -9)
22h	VOUT_TRIM*	R/W Word	2	Output voltage trimmed value (format: Linear 16, N= -9)
46h	IOUT_OC_FAULT_LIMIT*	R/W Word	2	Output overcurrent setting value (format: Linear 11, N= -2)
47h	IOUT_OC_FAULT_RESPONSE	R Byte	1	Define protection and response when an output overcurrent fault occurred
79h	STATUS_WORD	R Word	2	Summary status reporting
7Ah	STATUS_VOUT	R Byte	1	Output voltage status reporting
7Bh	STATUS_IOUT	R Byte	1	Output current status reporting
7Ch	STATUS_INPUT	R Byte	1	AC input voltage status reporting
7Dh	STATUS_TEMPERATURE	R Byte	1	Temperature status reporting
7Eh	STATUS_CML	R Byte	1	Communication, logic, Memory status reporting
80h	STATUS_MFR_SPECIFIC	R Byte	1	Manufacture specific status reporting
88h	READ_VIN	R Word	2	AC input voltage reading value (format: Linear 11, N= -1)
8Bh	READ_VOUT	R Word	2	Output voltage reading value (format: Linear 16, N= -9)
8Ch	READ_IOUT	R Word	2	Output current reading value (format: Linear 11, N= -2)
8Dh	READ_TEMPERATURE_1	R Word	2	Temperature 1 reading value (format: Linear 11, N= -3)
98h	PMBUS_REVISION	R Byte	1	The compliant revision of the PMBus (default: 11h for Rev. 1.1)
99h	MFR_ID	Block Read	12	Manufacturer's name
9Ah	MFR_MODEL	Block Read	12	Manufacturer's model name
9Bh	MFR_REVISION	Block Read	24	Firmware revision
9Ch	MFR_LOCATION	Block R/W	3	Manufacturer's factory location
9Dh	MFR_DATE	Block R/W	6	Manufacture date. (format: YYMMDD)
9Eh	MFR_SERIAL	Block R/W	12	Product serial number
BEh	SYSTEM_CONFIG	R/W Word	2	System setting
BFh	SYSTEM_STATUS	Read Word	2	System status

Note: Setting commands with * at the end support the EEP_OFF and EEP_CONFIG functions. For detailed information on how to enable them, please refer to SYSTEM_CONFIG (BEh).

Table 1-2

©Definition of Command BEh SYSTEM_CONFIG:

	Bit7	Bit6	Bit5	Bit4	Bit3	Bit2	Bit1	Bit0
High byte	-	-	-	-	-	EEP_OFF	EEP_CONFIG	
Low byte	-	-	-	-	-	OPERATION_INIT		PM_CTRL

Low byte

Bit 0: PM_CTRL: PMBus Control Selecting

0= Output voltage and current controlled by SVR/PV/PC(default)

1= Output voltage, current and remote ON/OFF controlled by PMBus (VOUT_TRIM, IOUT_FAULT_LIMIT, OPERATION)

Bit 1: 2 OPERATION_INIT: Initial Operational

0b00= Power on with 0x00: OFF

0b01= Power on with 0x80: ON (default)

0b10= Power on with the last setting

0b11= Not used

High Byte:

Bit 0:1 EEP_CONFIG: EEPROM Configuration

00: Immediate. Changes to parameters are written to EEPROM immediately (factory default)

01: 1 minute delay. Write changes to EEPROM if all parameters remain unchanged for 1 minute

10: 10 minute delay. Write changes to EEPROM if all parameters remain unchanged for 10 minutes

11: Reserved

Bit 2 EEP_OFF: EEPROM storage function ON/OFF

0: Enable. Parameters to be saved into EEPROM (factory default)

1: Disable. Parameters NOT to be saved into EEPROM

Note: Unsupported settings display with "0"

©Definition of Command BFh SYSTEM_STATUS:

	Bit7	Bit6	Bit5	Bit4	Bit3	Bit2	Bit1	Bit0
High byte	-	-	-	-	-	-	-	-
Low byte	-	EEPROM	INITIAL_STATE	ADL_ON	-	-	DC_OK	-

Low byte

Bit 1: DC_OK: The DC Output Status

0= DC output too low

1= DC output at a normal range

Bit 4 ADL_ON : Active Dummy Load Status

0= Active dummy load NOT activate

1= Active dummy load activate

Bit 5 INITIAL_STATE: Initial State Indication

0= The unit NOT in an initial state

1= The unit in an initial state

Note: Unsupported settings display with "0"

Bit 6 EEPER: EEPROM Access Error

0= EEPROM accessing normally

1= EEPROM access error

Note:

EEPER: When EEPROM Access Error occurs, the supply stops working and the LED indicator turns red. The supply needs to re-power on to recover after the error condition is removed.

1.2.1 PMBus Data Range and Tolerance

◎Display parameters

PMBus command		Model	Range	Tolerance
88h	READ_VIN	ALL	80~264V	±10V
8Bh	READ_VOUT	24V	0~28.8V	±0.24V
		36V	0~43.2V	±0.36V
		48V	0~57.6V	±0.48V
8Ch	READ_IOUT (Note. 1)	24V	0~125A	±2.6A
		36V	0~85A	±1.8A
		48V	0~63A	±1.3A
8Dh	READ_TEMPERATURE_1	ALL	-40~110°C	±5°C

Table 1-3

◎Control parameter

PMBus command		Model	Range	Tolerance	Default
01h	OPERATION	ALL	00h(OFF) / 80h(ON)	N/A	80h(ON)
21h	VOUT_COMMAND (Note. 2)	24V	24V	N/A	24V
		36V	36V	N/A	36V
		48V	48V	N/A	48V
22h	VOUT_TRIM (Note. 2)	24V	-12 ~ 4.8V	±0.24V	0V
		36V	-18 ~ 7.2V	±0.36V	0V
		48V	-24 ~ 9.6V	±0.48V	0V
46h	IOUT_OC_FAULT_LIMIT	24V	21 ~ 114.5A	±2.6A	114.5A
		36V	14 ~ 76.25A	±1.8A	76.25A
		48V	10.5 ~ 57.25A	±1.3A	57.25A
BEh	SYSTEM_CONFIG	ALL	N/A	N/A	02h

Table 1-4

Note:

1.READ_IOUT will display ZERO amp when output current is less than the values in the table below.

Model	Minimum readable current
24V	4.2A±1A
36V	2.75A±1A
48V	2.1A±1A

Table 1-5

2.When using PMBus to adjust output voltage, VOUT_COMMAND only can be used to display the rated voltage of the unit and cannot be written. It is VOUT_TRIM that provides voltage trimming function. Take UHP-2500-24 as an examples, to get a 12V output, please set value of VOUT_TRIM to -12V. Adjustable voltage range for each model is shown as below.

Model	Adjustable voltage range
24V	12 ~ 28.8V
36V	18 ~ 43.2V
48V	24 ~ 57.6V

Table 1-6

3.Owing to the limited write cycles of the EEPROM, it is advisable to consider using the SYSTEM_CONFIG (PM: BEh; CAN: 0x00C2) command to select an appropriate EEPROM writing logic, especially if communication settings are frequently altered.

1.2.2 Notes on PMBus

1. Insert a at least 50msec delay between commands

2. Examples for Format Conversion :

(1) LINEAR16 format : VOUT_COMMAND · VOUT_TRIM · READ_VOUT ·

Actual voltage = communication reading $V \times 2^N$. There are two definitions in the VOUT_MODE command that refer to N requirements.

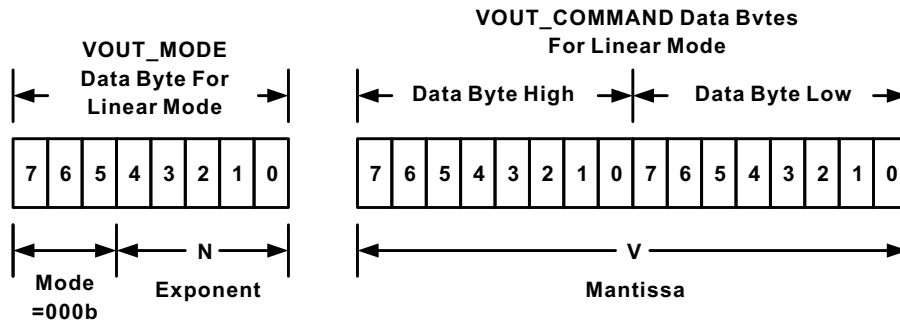

Linear Format Data Bytes

The Mode bits are set to 000b.

The Voltage, in volts, is calculated from the equation:

$$\text{Voltage} = V \cdot 2^N$$

Where:

Voltage is the parameter of interest in volts;

V is a 16 bit unsigned binary integer; and

N is a 5 bit two's complement binary integer.

EX: V_{o_real} (actual output voltage) = $V \times 2^N$, V is from READ_VOUT. N If VOUT_MODE = 0x17, meaning N is -9. READ_VOUT is 0x3000 12288, then $V_{o_real} = 12288 \times 2^{-9} = 24.0V$.

(2) LINEAR11 format : IOUT_OC_FAULT_LIMIT · READ_VIN · READ_IIN · READ_IOUT · READ_TEMPERATURE_1.

Actual value X = communication read value $Y \times 2^N$. Among them, the definition of the description column for each aircraft type is referred to.

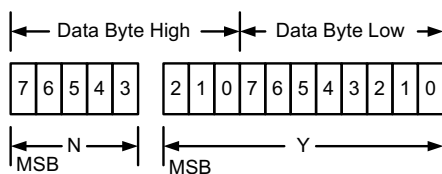

Linear Data Format Data Bytes Y, N and the "real world" value is:

The relation between

$$X = Y \cdot 2^N$$

Where, as described above:

X is the "real world" value;

Y is an 11 bit, two's complement integer; and

N is a 5 bit, two's complement integer.

Devices that use the Linear format must accept and be able to process any value of N.

EX: I_{o_real} (actual output current) = $Y \times 2^N$, Y is from READ_IOUT. N If READ_IOUT is 0xF188h, meaning N is -2 and Y is 0x0188. Y is 0x0188 \rightarrow 392, then $I_{o_real} = 392 \times 2^{-2} = 98.0A$.

1.2.3 Communication Example - Practical Operation of Power Supplu Mode

The following steps will describe how to set the UHP-2500-48 to 49V.

1. Set the address of the supply to "0". Set the DIP switch to ON/ON/ON.



2. Connect the SDA/SCL/GND to SDA(pin 11), SCL(pin 12) and GND-AUX(pin 9) of CN71.

ⓈSet speed: 100KHz

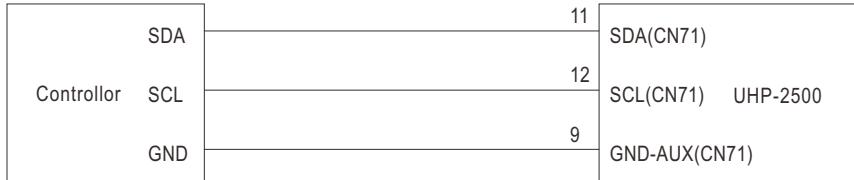

3. Communication function can be accessed immediately after UHP-2500 is connected to AC. First set it to communication mode.

Address(7 bit)	Operation	Command Code	Data
0x40	Write	0xBE	0x03, 0x00

Command code: 0xBE (SYSTEM_CONFIG)

Data: 03(Lo) + 00(Hi). Please refer to definition of SYSTEM_CONFIG for detailed information.

4. Set output voltage at 49V.

Address(7 bit)	Operation	Command Code	Data
0x40	Write	0x22	0x00, 0x02

Command code: 0x22 (VOUT_TRIM)

Data: 1V → 0x0200 → 0x02, 0x00

NOTE: VOUT_TRIM is LINEAR16 format

5. It is recommended to review all of the settings and parameters using the appropriate commands. In the event that they do not meet your requirements, you may rewrite them as needed.

NOTE: Read VOUT_TRIM to check whether output voltage was set to a proper level.

Read READ_VOUT

Address(7 bit)	Operation	Command Code
0x40	Read	0x22

The unit returns data below

Address(7 bit)	Data
0x40	0x00, 0x02

Data: 0x00(Lo) + 0x02(Hi) → 0x0200 → $512 \times 2^{-9} = 1V$. $48 + 1V = 49V$, the result is correct.

6. Finally, check whether Remote ON-OFF (PIN5) and +12V-AUX (PIN7) pins of the CN71 connector are short-circuited if there is no output voltage.

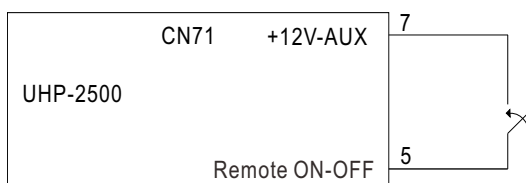

1.3 CANBus Communication Interface

⊙Physical layer specification

This protocol follows CAN ISO-11898 with Baud rate of 250Kbps.

⊙Data Frame

This protocol uses Extended CAN 29-bit identifier frame format or CAN 2.0B.

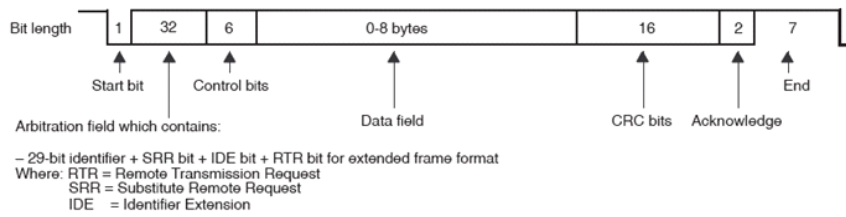

⊙Communication Timing

Min. request period (Controller to UHP-2500): 50mSec °

Max. response time (UHP-2500 to Controller): 12.5mSec °

Min. packet margin time (Controller to UHP-2500): 12.5mSec °

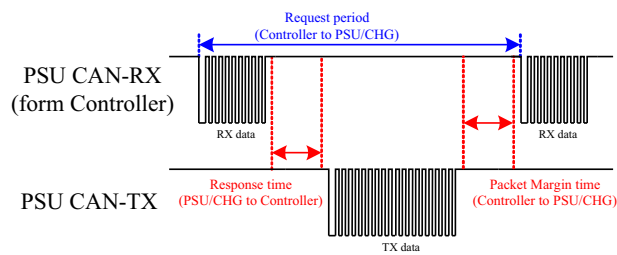

⊙Data Field Format

Controller to UHP-2500

Write:

Data field bytes



Read:

Data field bytes



UHP-2500 to Controller

Response:

Data field bytes



NOTE: UHP-2500 will not send data back when writing parameters, such as VOUT_SET

1.3.1 CANBus Command list

Command Code	Command Name	Transaction Type	# of data Bytes	Description
0x0000	OPERATION	R/W	1	ON/OFF control ON: 01h OFF: 00h
0x0020	VOUT_SET*	R/W	2	Output voltage set (format: value, F=0.01)
0x0030	IOUT_SET*	R/W	2	Output current set (format: value, F=0.01)
0x0040	FAULT_STATUS	R	2	Abnormal status
0x0050	READ_VIN	R	2	Input voltage read value (format: value, F=0.1)
0x0060	READ_VOUT	R	2	Output voltage read value (format: value, F=0.01)
0x0061	READ_IOUT	R	2	Output current read value (format: value, F=0.01)
0x0062	READ_TEMPERATURE_1	R	2	Internal ambient temperature (format: value, F=0.1)
0x0080	MFR_ID_B0B5	R	6	Manufacture's name
0x0081	MFR_ID_B6B11	R	6	Manufacture's name
0x0082	MFR_MODEL_B0B5	R	6	Manufacture model name
0x0083	MFR_MODEL_B6B11	R	6	Manufacture model name
0x0084	MFR_REVISION_B0B5	R	6	Firmware version
0x0085	MFR_LOCATION_B0B2	R	3	Manufacture place
0x0086	MFR_DATE_B0B5	R	6	Manufacture date
0x0087	MFR_SERIAL_B0B5	R	6	Manufacture serial number
0x0088	MFR_SERIAL_B6B11	R	6	Manufacture serial number
0x00C0	SCALING_FACTOR	R	6	Scaling ratio
0x00C1	SYSTEM_STATUS	R	2	System status
0x00C2	SYSTEM_CONFIG	R/W	2	System configuration

Note: Setting commands with * at the end support the EEP_OFF and EEP_CONFIG functions. For detailed information on how to enable them, please refer to SYSTEM_CONFIG (0x00C2).

Table 1-7

Data conversion:

The conversion of setting and reading values is defined as following:

Actual value = Communication reading value × Factor (F value). Among them, Factor needs to refer to the definition of SCALING_FACTOR in each model list.

EX: V_{o_real} (actual DC voltage) = READ_VOUT × Factor.

If the Factory of READ_VOUT of a certain mode is 0.01, the communication reading value is 0x0960 (hexadecimal)→2400(decimal), then $V_{DC_real} = 2400 \times 0.01 = 24.0V$.

1.3.2 Definition and contents of CANBus Command list

©Definition of Command FAULT_STATUS(0x0040) :

	Bit7	Bit6	Bit5	Bit4	Bit3	Bit2	Bit1	Bit0
High byte	-	-	-	-	-	-	-	-
Low byte	HI_TEMP	OP_OFF	AC_FAIL	SHORT	OLP	OVP	OTP	-

Low byte

Bit 1 OTP : Over temperature protection

0 = Internal temperature normal

1 = Internal temperature abnormal

Bit 2 OVP : DC over voltage protection

0 = DC voltage normal

1 = DC over voltage protected

Bit 3 OLP : DC over current protection

0 = DC current normal

1 = DC over current protected

Bit 4 SHORT : Short circuit protection

0 = Shorted circuit do not exist

1 = Shorted circuit protected

Bit 5 AC_FAIL : AC abnormal flag

0 = AC input range normal

1 = AC input range abnormal

Bit 6 OP_OFF : DC status

0 = DC output turned on

1 = DC output turned off

Bit 7 HI_TEMP : Internal high temperature protection

0 = Internal temperature normal

1 = Internal temperature abnormal

Note: Unsupported settings displays with "0"

©MFR_ID_B0B5 (0x0080) is the first 6 codes of the manufacturer's name (ASCII); MFR_ID_B6B11 (0x0081) is the last 6 codes of the manufacturer's name (ASCII)

EX: Manufacturer's name is MEANWELL MFR_ID_B0B5 is MEANWE ; MFR_ID_B6B11 is LL

MFR_ID_B0B5					
Byte 0	Byte 1	Byte 2	Byte 3	Byte 4	Byte 5
0x4D	0x45	0x41	0x4E	0x57	0x45

MFR_ID_B6B11					
Byte 0	Byte 1	Byte 2	Byte 3	Byte 4	Byte 5
0x4C	0x4C	0x20	0x20	0x20	0x20

©MFR_MODEL_B0B5 (0x0082) is the first 6 codes of the manufacturer's model name (ASCII);
MFR_MODEL_B6B11 (0x0083) is the last 6 codes of the manufacturer's model name (ASCII)
EX: Model names is UHP-2500-48 → MFR_MODEL_B0B5 is UHP-25 ; MFR_MODEL_B6B11 is 00-48

MFR_MODEL_B0B5					
Byte 0	Byte 1	Byte 2	Byte 3	Byte 4	Byte 5
0x55	0x48	0x50	0x2D	0x32	0x35

MFR_ID_B6B11					
Byte 6	Byte 7	Byte 8	Byte 9	Byte 10	Byte 11
0x30	0x30	0x2D	0x34	0x38	0x20

©MFR_REVISION_B0B5 (0x0084) is the firmware revision (hexadecimal).
A range of 0x00 (R00.0)~0xFE (R25.4) represents the firmware version of an MCU; 0xFF represents no MCU existed.

EX: The supply has two MCUs, the firmware version of the MCU number 1 is version R25.4 (0xFE), the MCU number 2 is version R10.5 (0x69)

Byte 0	Byte 1	Byte 2	Byte 3	Byte 4	Byte 5
0xFE	0x69	0xFF	0xFF	0xFF	0xFF

©MFR_DATE_B0B5 (0x0086) is manufacture date (ASCII)

EX: MFR_DATE_B0B5 is 180101, meaning 2018/01/01

Byte 0	Byte 1	Byte 2	Byte 3	Byte 4	Byte 5
0x31	0x38	0x30	0x31	0x30	0x31

©MFR_SERIAL_B0B5 (0x0087) and MFR_SERIAL_B6B11 (0x0088) are defined as manufacture date and manufacture serial number (ASCII)

EX: The first unit manufactured on 2018/01/01→MFR_SERIAL_B0B5: 180101 ; MFR_SERIAL_B6B11: 000001

Byte 0	Byte 1	Byte 2	Byte 3	Byte 4	Byte 5
0x31	0x38	0x30	0x31	0x30	0x31

Byte 6	Byte 7	Byte 8	Byte 9	Byte 10	Byte 11
0x30	0x30	0x30	0x30	0x30	0x31

©SCALING_FACTOR(0x00C0) :

Bit7~Bit0								
byte4~5	Reserved							
	Bit7	Bit6	Bit5	Bit4	Bit3	Bit2	Bit1	Bit0
byte3	-				-			
	Bit7	Bit6	Bit5	Bit4	Bit3	Bit2	Bit1	Bit0
byte2	-				TEMPERATURE_1 Factor			
	Bit7	Bit6	Bit5	Bit4	Bit3	Bit2	Bit1	Bit0
byte1	-				VIN Factor			
	Bit7	Bit6	Bit5	Bit4	Bit3	Bit2	Bit1	Bit0
byte0	IOUT Factor				VOUT Factor			

byte0:

Bit 0:3 VOUT Factor : The factor of output voltage

0x0=Output voltage relevant commands not supported

0x4=0.001

0x5=0.01

0x6=0.1

0x7=1.0

0x8=10

0x9=100

Bit 4:7 IOUT Factor : The Factor of DC current

0x0=Output current relevant commands not supported

0x4=0.001

0x5=0.01

0x6=0.1

0x7=1.0

0x8=10

0x9=100

byte1:

Bit 0:3 VIN Factor : The Factor of AC input voltage

0x0=AC input relevant commands not supported

0x4=0.001

0x5=0.01

0x6=0.1

0x7=1.0

0x8=10

0x9=100

byte2:

Bit 0:3 TEMPERATURE_1 Factor : The Factor of internal ambient temperature

0x0=internal ambient temperature relevant commands not supported

0x4=0.001

0x5=0.01

0x6=0.1

0x7=1.0

0x8=10

0x9=100

©SYSTEM_STATUS(0x00C1) :

	Bit7	Bit6	Bit5	Bit4	Bit3	Bit2	Bit1	Bit0
High byte	-	-	-	-	-	-	-	-
Low byte	-	EEPER	INITIAL- LSTATE	ADL_ON	-	-	DC_OK	-

Low byte

Bit 1 DC_OK : Secondary DD output voltage status

0 = Secondary DD output voltage status TOO LOW

1 = Secondary DD output voltage status NORMAL

Bit 4 ADL_ON : Active dummy load control status

0 = Active dummy load off/function not supported

1 = Active dummy load on

Bit 5 INITIAL_STATE : Device initialized status

0 = NOT in initialization status

1 = In initialization status

Bit 6 EEPER : EEPROM data access error

0 = EEPROM data access normal

1 = EEPROM data access error

Note: Unsupported settings displays with "0"

©SYSTEM_CONFIG(0x00C2) :

	Bit7	Bit6	Bit5	Bit4	Bit3	Bit2	Bit1	Bit0
High byte	-	-	-	-	-	EEP_OFF	EEP_CONFIG	
Low byte	-	-	-	-	-	OPERATION_INIT		CAN_CTRL

Low Byte:

Bit 0 CAN_CTRL : CANBus communication control status

0 = The output voltage/current defined by control over SVR/PV/PC (factory default)

1 = The output voltage, current, ON/OFF control defined by control over

CANBus (VOUT_SET, IOUT_SET, OPERATION)

Bit 1:2 OPERATION_INIT : Pre-set value of power on operation command

0b00 = Power OFF, pre-set 0x00(OFF)

0b01 = Power ON, pre-set 0x01(ON) (factory default)

0b10 = Pre-set is previous set value

0b11 = not used, reserved

High Byte:

Bit 0:1 EEP_CONFIG: EEPROM Configuration

00: Immediate. Changes to parameters are written to EEPROM immediately (factory default)

01: 1 minute delay. Write changes to EEPROM if all parameters remain unchanged for 1 minute

10: 10 minute delay. Write changes to EEPROM if all parameters remain unchanged for 10 minutes

11: Reserved

Bit 2 EEP_OFF: EEPROM storage function ON/OFF

0: Enable. Parameters to be saved into EEPROM (factory default)

1: Disable. Parameters NOT to be saved into EEPROM

Note: Unsupported settings displays with "0"

1.3.3 CANBus Value Range and Tolerance

◎Display parameters

	CANBus command	Model	Display value range	Tolerance
0x0050	READ_VIN	ALL	80 ~ 264V	±10V
0x0060	READ_VOUT	24V	0 ~ 28.8V	±0.24V
		36V	0 ~ 43.2V	±0.36V
		48V	0 ~ 57.6V	±2.6V
0x0061	READ_IOUT (Note. 1)	24V	0 ~ 180A	±1.3A
		36V	0 ~ 135A	±1.3A
		48V	0 ~ 90A	±3A
0x0062	READ_TEMPERATURE_1	ALL	-40 ~ 100°C	±5°C

◎Control parameters

	CANBus command	Model	Adjustable range	Tolerance	Default
0x0000	OPERATION	ALL	0x00(OFF)/0x01(ON)	N/A	0x01
0x0020	VOUT_SET	24V	12 ~ 28.8V	±0.24V	24V
		36V	18 ~ 43.2V	±0.36V	36V
		48V	24 ~ 57.6V	±0.48V	48V
0x0030	IOUT_SET	24V	20.84 ~ 114.62A	±2.6A	114.62A
		36V	13.88 ~ 76.34A	±1.8A	76.34A
		48V	10.42 ~ 57.31A	±1.3A	57.31A
0x00C2	SYSTEM_CONFIG 0x0002	ALL	N/A	N/A	0x0002

Note:

1. READ_IOUT will display ZERO amp when output current is less than the values in the table below.

Model	Minimum readable current
24V	4.2A±1A
36V	2.75A±1A
48V	2.1A±1A

2. Owing to the limited write cycles of the EEPROM, it is advisable to consider using the SYSTEM_CONFIG (PM: BEh; CAN: 0x00C2) command to select an appropriate EEPROM writing logic, especially if communication settings are frequently altered.

1.3.4 CANBus Communication example

1.3.4.1 Sending command

The master adjusts output voltage of the unit with address "01" to 30V.

CAN ID	DLC (data length)	Command code	Parameters
0x000C0101	0x4	0x2000	0xB80B

Command code: 0x0020 (VOUT_SET) → 0x20(Lo) + 0x00(Hi)

Parameters: 30V → 3000 → 0x0BB8 → 0xB8(Lo) + 0x0B(Hi)

NOTE: Conversion factor for VOUT_SET is 0.01, so $\frac{30V}{F=0.01} = 3000$

1.3.4.2 Reading data or status

The master reads operation setting from the unit with address "00".

CAN ID	DLC (data length)	Command code
0x000C0100	0x2	0x0000

The unit with address "00" returns data below

CAN ID	DLC (data length)	Command code	Parameters
0x000C0000	0x3	0x0000	0x01

Parameters: 0x01 ON, meaning that the unit with address "00" is operating.

1.3.4.3 Communication Example - Practical Operation of Power Supply Mode

The following steps will describe how to set the UHP-2500-48 to 56V.

1. Set the address of the supply to "0". Set the DIP switch to ON/ON/ON.



2. Connect the CANH/CANL pins of the master to the corresponding CANH(PIN11) and CANL(PIN12) pins of the CN71 connector on the supply. It is recommended to establish a common ground for the communication system to increase its communication reliability by using GND-AUX (PIN9) of CN71.

Ⓞ Set baud rate: 250kbps, type: extended

Ⓞ Adding a 120Ω terminal resistor to both the controller and power supply ends can increase communication stability

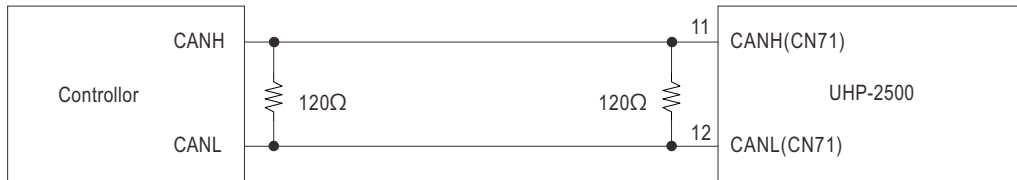

3. Communication function can be accessed immediately after UHP-2500 is connected to AC. First set it to communication mode.

CANID	DLC(data length)	Command Code	Parameters
0x000C0100	0x04	0xC200	0x0300

Command code: 0x00C2 (SYSTEM_CONFIG)

Data: 03(Lo) + 00(Hi). Please refer to definition of SYSTEM_CONFIG for detailed information.

4. Set output voltage at 56V.

CANID	DLC(data length)	Command Code	Parameters
0x000C0100	0x04	0x2000	0xE015

Command code: 0x0020(VOUT_SET)

Data: 56V → 5600 → 0x15E0 → 0xE0(Lo) + 0x15(Hi)

NOTE: Conversion factor for CURVE_CV is 0.01, so $\frac{56V}{F=0.01} = 5600$

5. It is recommended to review all of the settings and parameters using the appropriate commands. In the event that they do not meet your requirements, you may rewrite them as needed.

EX: Read READ_VOUT to check whether output voltage was set to a proper level.

Read READ_VOUT

CANID	DLC(data length)	Command Code
0x000C0100	0x02	0x2000

The unit returns data below

CANID	DLC(data length)	Command Code	Parameters
0x000C0000	0x04	0x2000	0xE015

Data: 0xE0(Lo) + 0x15(Hi) → 0x15E0 → 5600 x 0.01 = 56V.

6. Finally, check whether Remote ON-OFF (PIN5) and +12V-AUX (PIN7) pins of the CN71 connector are short-circuited if there is no output voltage.

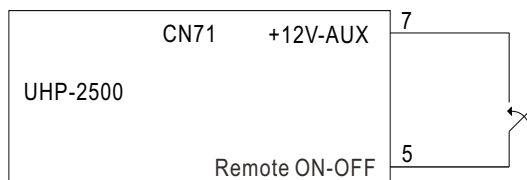

2.Factory Resetting

Users can follow the steps below to restore factory settings for PMBus commands: 01h, 22h, 22h, 46h, BEh ; CANBus commands: 0x0000, 0x0020, 0x0030, 0x00C2) to the default settings.

(1) Set all DIP switch positions to ON.

(2) Power on in REMOTE OFF mode (no output at this step).

(3) After power on, in 15 seconds, switch all DIP switch from ON to OFF and then switch ALL back to ON position again.

(4) Green LED will blink 3 times if set successfully.

(5) Factory default setting will be restored after re-power on.

DIP switch diagram is as shown below.



明緯企業股份有限公司

MEAN WELL ENTERPRISES CO., LTD.

248 新北市五股區五權三路28號

No.28, Wuquan 3rd Rd., Wugu Dist., New Taipei City 248, Taiwan

Tel: 886-2-2299-6100 Fax: 886-2-2299-6200

<http://www.meanwell.com> E-mail: info@meanwell.com

Your Reliable Power Partner